

AIR OPERATED DOUBLE DIAPHRAGM PUMPS



TECHNOLOGY EXCELLENCE

ENVIRONMENT Concerned

Metal die-casting and thermoplastic materials moulding are optimally industrialized and produced using energy efficient and reliable resources.



STATE-OF-THE-ART Machinery

We produce all components in-house, using the most advanced equipment.

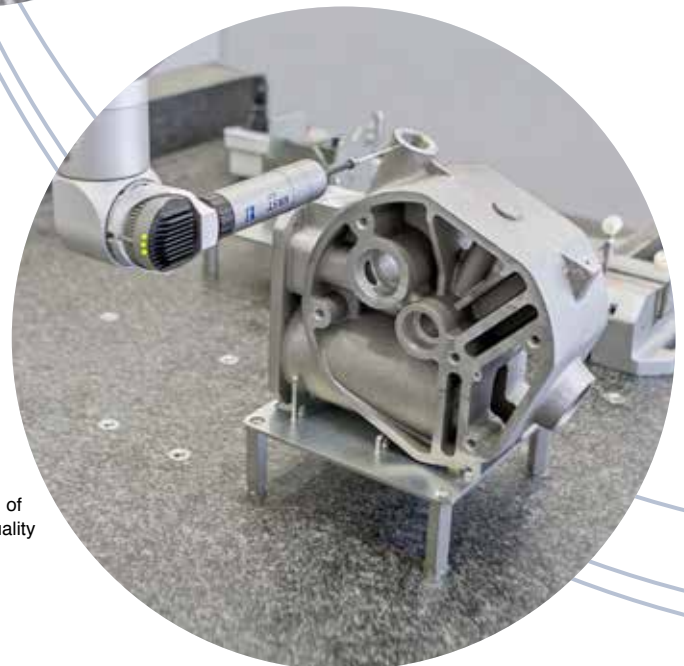

QUALITY First

Automated measuring of parts for consistent quality assurance.



SAMOA Headquarters and
Technical Centre in Gijón (Spain)

SAMOA: LEADING THROUGH INNOVATION

SAMOA, a privately owned company, is a **leading European manufacturer of Lubrication and Fluid Handling Equipment**. SAMOA products are used for transferring, dispensing, dosing, and recovering different types of fluids in multiple industries and applications. SAMOA designs and manufactures **a wide variety of products that includes air operated piston and double diaphragm pumps**, volume flow meters, delivery guns, electronic components used in inventory control systems, hose reels, hand pumps and accessories for these products.

Product research and development is a fundamental part of SAMOA's philosophy. We are in permanent contact with the market to identify new customer needs, that we satisfy with existing product improvement and new product development.

SAMOA's headquarters have been in Gijón, on the Spanish North Coast, for over 60 years. SAMOA's manufacturing facilities are modern and equipped with the latest state-of-the-art production equipment and technology. We are **committed to design and manufacturing excellence, environmental sustainability and a healthy and safe workplace**; our work processes and facilities are consequently ISO 9001, ISO 14001 and ISO 45001 certified.

Our products are available through a network of **fully owned subsidiaries and knowledgeable** distributors. This global network provides a sales and consulting service, to identify the products that best meet our customers needs, and provide both before and after sales service to ensure complete product satisfaction.

Our continuous product improvement process ensures that **our products meet customer requirements worldwide**, including in even the most demanding applications and environments. As a result, we are proud to say that SAMOA products are reliably working away, night and day, in more than 100 countries.



**INDIVIDUALLY
Tested**

All pumps are dry, wet, vacuum,
and dead-head verified.

**INTERCHANGEABLE
Parts**

Consistent assembly.



AIR OPERATED DOUBLE DIA

WORKING PRINCIPLE OF AN AODD PUMP

SAMOA Pivot Universal Pumps (UP) are air operated double diaphragm reciprocating pumps. They have two opposing pump volumes divided by a diaphragm between the air and the liquid chambers. The diaphragms are connected to a shaft and during one pumping stroke, the fluid (blue) is suctioned into one liquid chamber, while simultaneously the fluid in the opposite liquid chamber (red) is discharged.

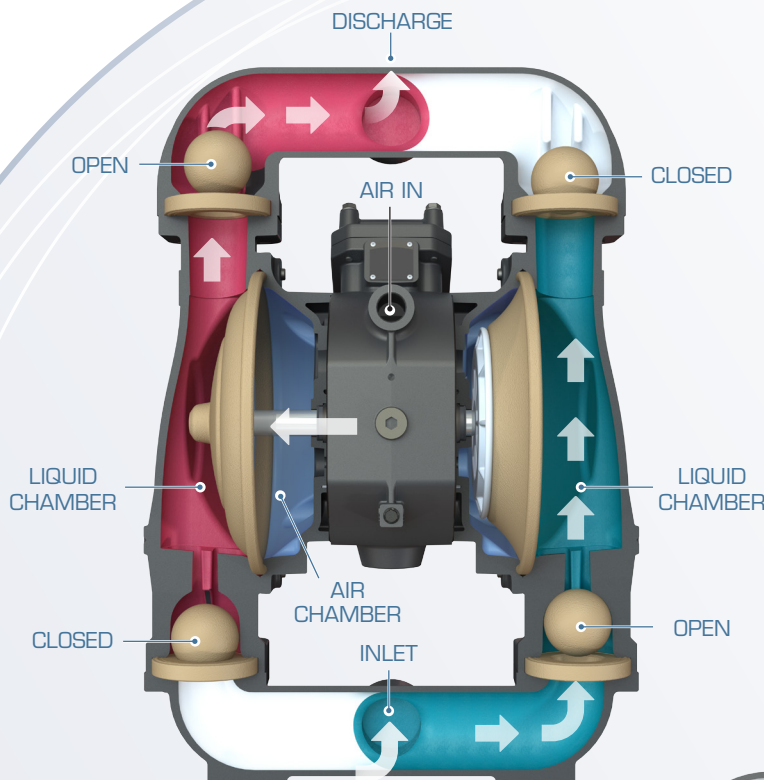

SUCTION STROKE (BLUE)

The air valve in the center of the pump fills the left air chamber with compressed air, causing the right diaphragm to move creating fluid suction. This action lifts the lower check valve allowing fluid to flow into the liquid chamber. Simultaneously, the left chamber is in Discharge Stroke (red).

DISCHARGE STROKE (RED)

The air valve alternates the air flow, which now fills the right air chamber, causing the upper check valve to open and discharge fluid. Simultaneously, the left chamber is working in the Suction Stroke (blue).

A suction stroke and a discharge stroke constitute a complete pump cycle. The pump may take several cycles to complete prime depending on the application conditions.

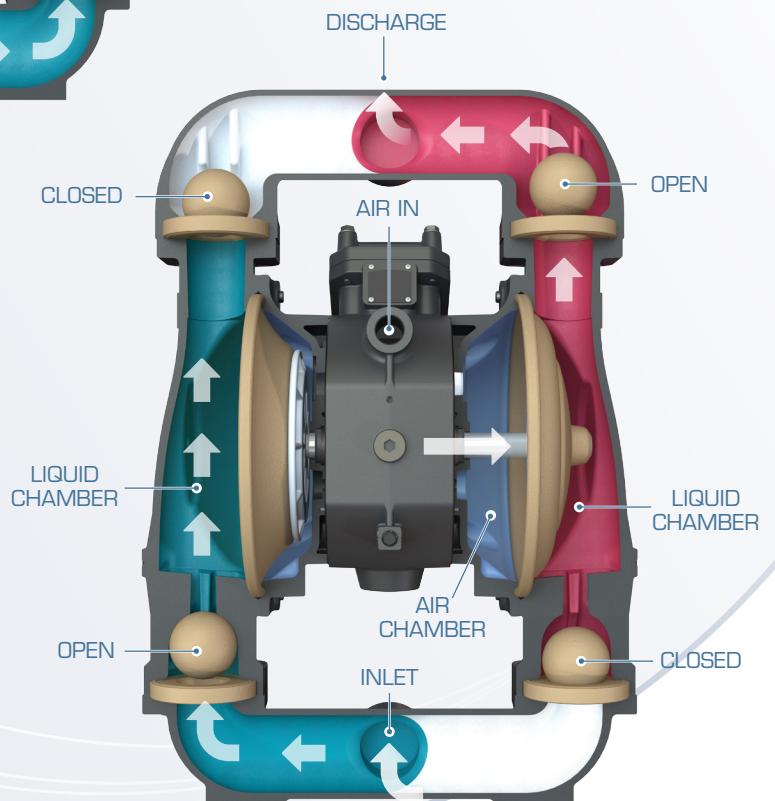

DIAPHRAGM (AODD) PUMPS

INSTALLATION OF AODD PUMPS

AODD pumps are suitable for a wide variety of applications:

- Fixed installations in process applications.
- Portable or mobile units, for easy transport to different areas of use.

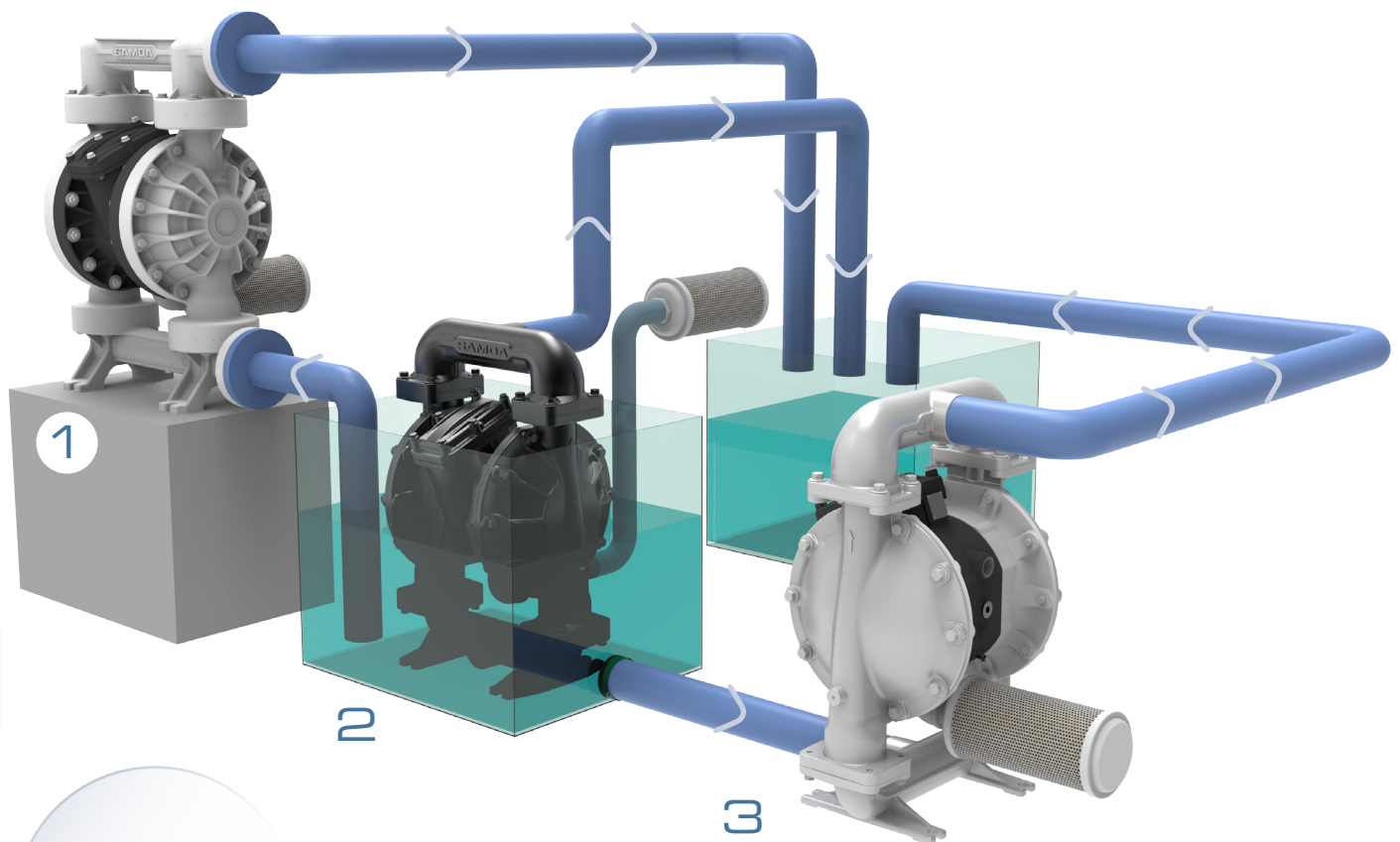

1. SUCTION LIFT

- Dry self-priming.
- Max lift up to 8,3 m (28') (water) with an adequate filler suction pipe.

2. SUBMERGED

- Pump can be totally submerged in the pumped liquid.
- Air exhaust outlet must be above the fluid level.
- Pump central body materials must be compatible with the pumped liquid.

3. FLOODED SUCTION

- Most common installation.
- Adequate for viscous fluids.
- Suction side inlet pressure should not exceed max. 0,7 bar / 10 psi and 7 m - 23' water column.

UP: PIVOT UNIVERSAL PUMP

The new SAMOA Pivot Universal Pump (UP) combines a Universal design with a unique frictionless Pivot-Shaft Air Valve to provide maximum performance and energy efficiency, which exceeds performance expectations.

ADVANTAGES OF AODD PUMPS

- Pump can run dry with no damage.
- Dry self-priming.
- Can pump fluids with suspended solids.
- Best pump for abrasive, corrosive and shear sensitive fluids.
- Air driven pump, no electricity required, no electrical hazard.
- Can be submerged completely with no performance or safety issues.
- On-demand operation. Pump stops when fluid outlet closes and automatically starts when the fluid outlet opens.
- Fluid flow and pressure are fully adjustable with only an air pressure regulator.
- No dynamic mechanical seals or packings.



ADDITIONALLY, UP SERIES PUMPS OFFER:

- HIGHER EFFICIENCY:** Maximum fluid flow with reduced air consumption, versus competitive pumps.
- INCREASED RELIABILITY:** No stall, no icing, and reliable start-up even with the lowest air pressure.
- MINIMAL VIBRATION AND PULSATION:** Due to the fast action frictionless Pivot-Shaft Air Valve.
- BOLTED CONSTRUCTION:** Provides improved sealing to eliminate pump leaks. Same size bolts for ease of maintenance.
- EASIER SERVICING:** Components designed for a simpler and easier maintenance, with reduced number of parts.
- UNIVERSAL PUMP:** Matches relative dimension of main competitive brands. Direct replacement for existing installed pumps.
- SUPERB ABRASION RESISTANCE:** Optimized fluid paths and manifolds reduce fluid speed and minimize wear caused by abrasion.
- SILENT OPERATION:** UP pumps air valve produces less noise than competition pumps.

ADVANTAGES

AODD PUMPS VS. OTHER PUMP TECHNOLOGIES



PUMP TYPES

AODD Diaphragm

Piston / Plunger

Peristaltic Hose

Lobe

Vane

Gear

Centrifugal

Pump Classification PD = Positive Displacement Pump	PD Reciprocating	PD Reciprocating	PD Rotary	PD Rotary	PD Rotary	PD Rotary	Kinetic

PUMPED FLUID CHARACTERISTICS

SUSPENDED SOLIDS No pump or product damage	▲	▼	▬	▼	▲	▬	▬
ABRASIVE SLUDGE & SLURRIES Low internal velocities-No damage	▲	▼	▲	▼	▼	▼	▲
CORROSIVE FLUIDS Compatible pump materials	▲	▼	▲	▬	▼	▼	▼
SHEAR SENSITIVITY Low shear and product separation	▲	▼	▼	▲	▼	▼	▼

PUMP OPERATION

DRY-RUNNING CAPABILITY No pump or system damage	▲	▲	▲	▼	▬	▼	▼
DRY SELF-PRIMING High suction-lift	▲	▬	▼	▼	▼	▼	▼
PORTABLE & SUBMERSIBLE Integral pump with air motor	▲	▼	▼	▼	▼	▼	▬
COOL OPERATION No heat build-up during transfer	▲	▬	▬	▬	▬	▬	▬
SAFETY (ATEX models) Air Driven. No electrical hazard	▲	▬	▬	▬	▬	▬	▬

PUMP COST ADVANTAGES

ON-DEMAND OPERATION Bypass and relief valves cost savings	▲	▲	▬	▬	▬	▬	▬
ADJUSTABLE FLOW & PRESSURE Additional regulation costs savings	▲	▬	▬	▬	▬	▬	▬
DYNAMIC & MECHANICAL SEALS Replacement and maintenance cost savings	▲	▼	▼	▼	▼	▼	▼
NO ELECTRICAL INSTALLATION Intrinsically safe, cost savings	▲	▼	▼	▼	▼	▼	▼
INITIAL PURCHASE PRICE Compared to other pump types	▲	▼	▼	▼	▼	▼	▼

▲ = Excellent

▬ = With limitations

▼ = Not recommended

APPLICATIONS AND INDUSTRIES

PROCESS INDUSTRY



MINING



WATER/WASTE WATER



ENERGY INDUSTRY



UP PUMPS CODING SYSTEM



Examples: **UP20A-BAC-HHC**
UE10B-FPS-PTZ-H

PUMP TYPE & SIZE

1 PUMP TYPE

UP = Universal Pump (Bolted type)
UE = Universal Pump with electronic interface

2 PUMP SIZE – Connection Ports (Ø)

03 - 3/8" (10 mm)
05 - 1/2" (12.5 mm)
10 - 1" (25 mm)
20 - 2" (51 mm)
30 - 3" (76 mm)

AIR MOTOR BODY SPECIFICATIONS

3 AIR MOTOR

A = Aluminium
B = Conductive Polypropylene (ATEX)
L = Conductive Polypropylene (ATEX) with air chambers in AISI 316 Stainless Steel
S = AISI 316 Stainless Steel

HOUSINGS SPECIFICATIONS

4 FLUID CONNECTION PORTS

B = BSP (Threaded - Central Location)
N = NPT (Threaded - Central Location)
C = ANSI/DIN (Flanged-Central Location)
F = ANSI/DIN (Flanged-Side Location)
P = BSP (Threaded - Lateral Location)
T = NPT (Threaded - Lateral Location)

5 FLUID CHAMBERS/MANIFOLDS

A = Aluminium
D = Conductive Acetal (ATEX)
F = Ductile Iron
P = Polypropylene
B = Conductive Polypropylene (ATEX)
S = AISI 316 Stainless Steel
W = PVDF

6 HARDWARE (Bolts & Nuts)

C = Carbon Steel
S = Stainless Steel

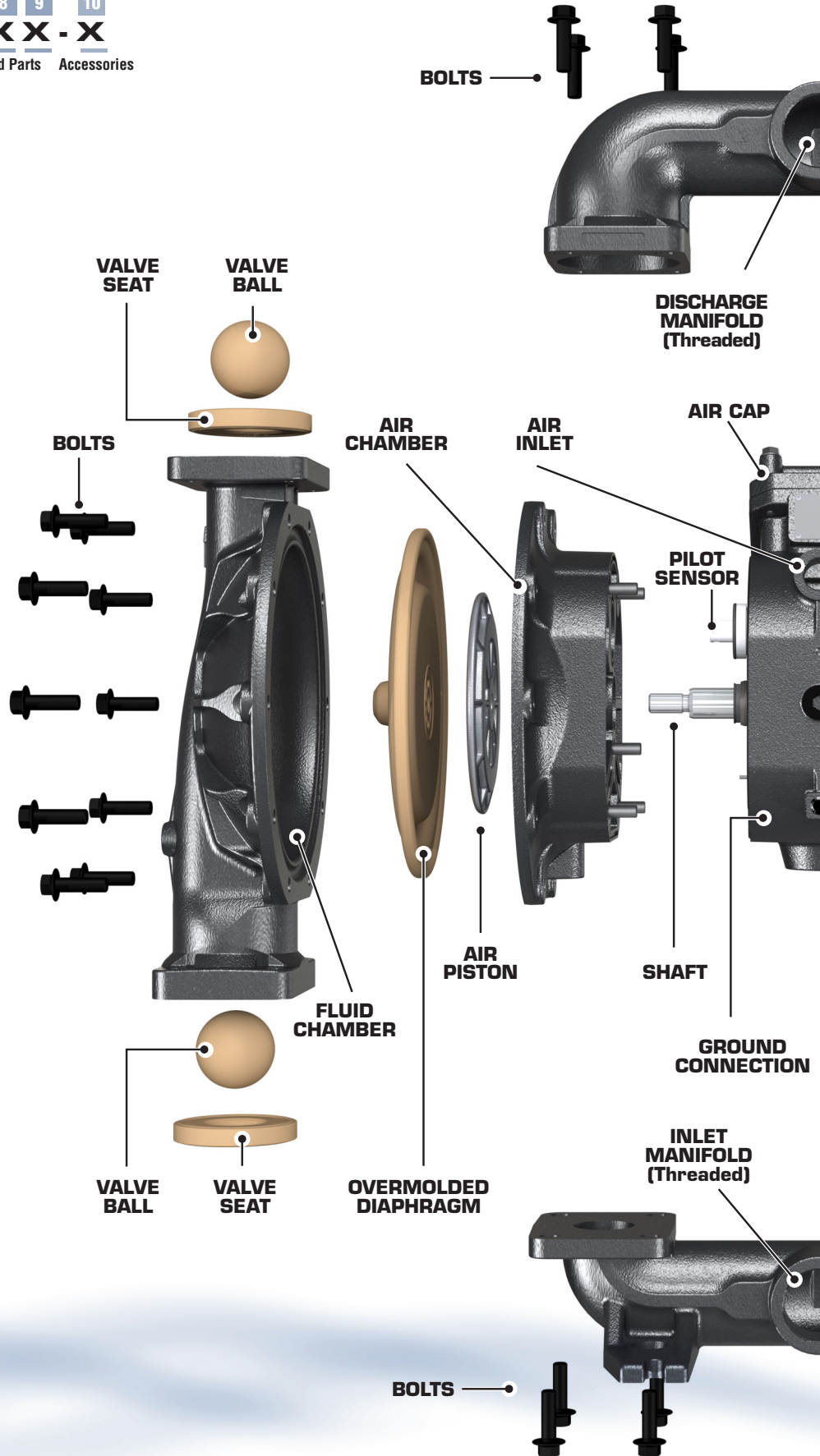

FLEXIBLE, MODULAR DESIGN

Flexible and modular design pumps concept for the widest product range and for all pump sizes.

Quick change of wetted parts (diaphragms, seats and balls) makes any pump suitable for use with other fluids.

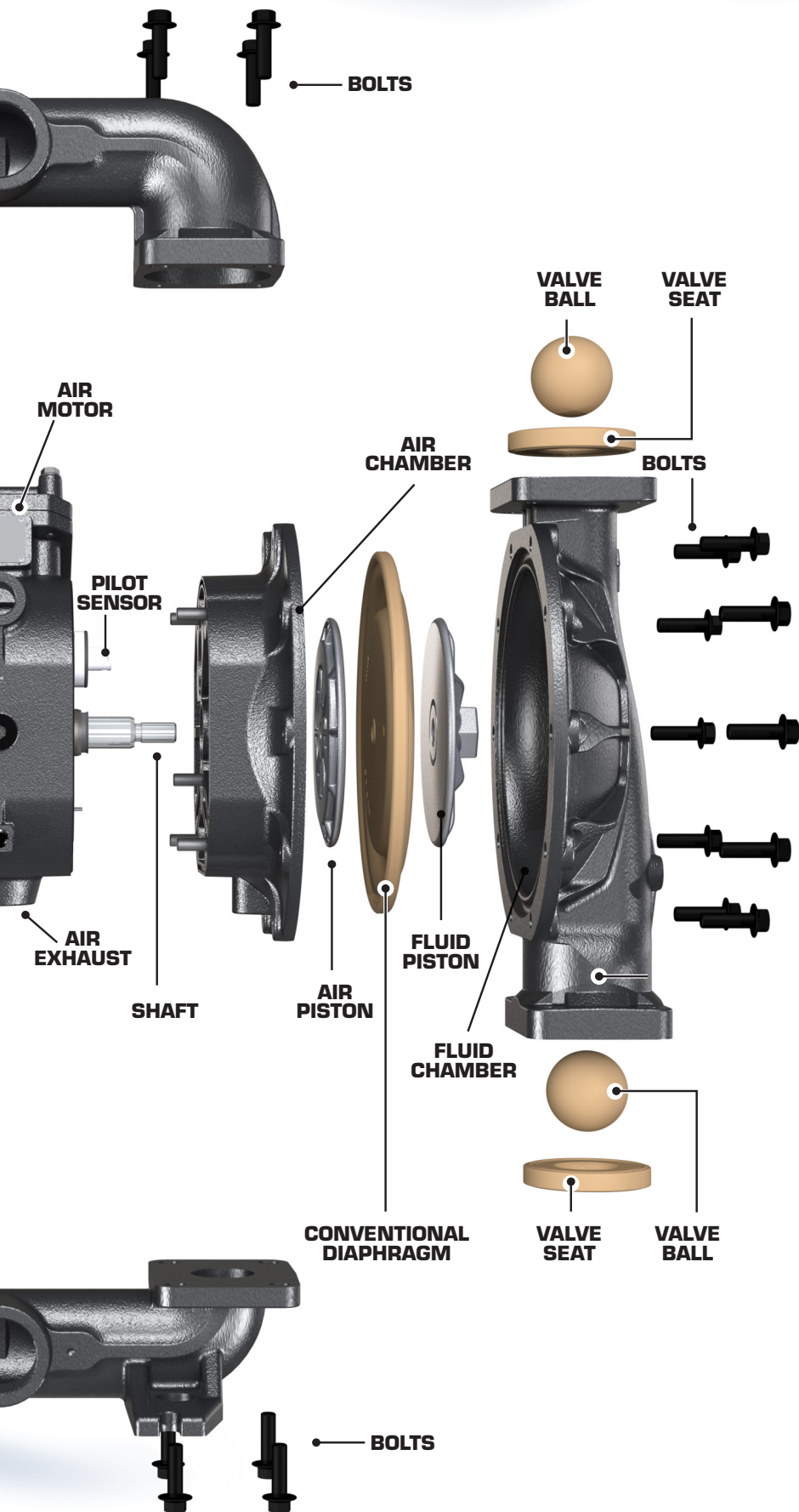

WETTED PARTS SPECIFICATIONS

7 VALVE SEATS MATERIAL OPTIONS

- A = Aluminium
- C = Acetal
- D = AISI 440 Hardened Stainless Steel
- H = Hytrel®
- M = Santoprene®
- N = NBR (Buna-N)
- P = Polypropylene
- S = AISI 316 Stainless Steel
- T = PTFE (Teflon®)

8 VALVE BALLS MATERIAL OPTIONS

- H = Hytrel®
- C = Acetal
- M = Santoprene®
- N = NBR (Buna-N)
- S = AISI 316 Stainless Steel
- T = PTFE (Teflon®)
- V = FKM (Viton®)

9 DIAPHRAGM MATERIAL OPTIONS

Conventional Diaphragm (with exposed fluid piston)

- A = Santoprene®
- C = Hytrel®
- G = NBR (Buna-N)
- V = FKM (Viton®)
- U (plastic pump versions) = PTFE with Santoprene® backer
- Z (metal pump versions) = PTFE with Santoprene® backer

Overmolded one piece Diaphragm (inserted fluid piston)

- M = Santoprene®
- H = Hytrel®
- T = PTFE/EPDM-Bonded
- N = NBR (Buna-N)

ACCESSORIES

10 ACCESSORIES (For UE pumps only)

For use together with U-pump controller except where otherwise indicated.

- A = Diaphragm leak detectors
- B = Diaphragm leak detectors (ATEX)
- C = Stroke sensor
- D = Stroke sensor (PLC based controller)
- E = Stroke sensor (ATEX)
- F = Diaphragm leak detectors + Stroke sensor
- G = Diaphragm leak detectors + Stroke sensor (PLC based controllers)
- H = Diaphragm leak detectors + Stroke sensor (ATEX)

Not all material options are available to all pump sizes.

UP PUMP SIZE SELECTION &

PUMP SIZE - PERFORMANCE CHARTS

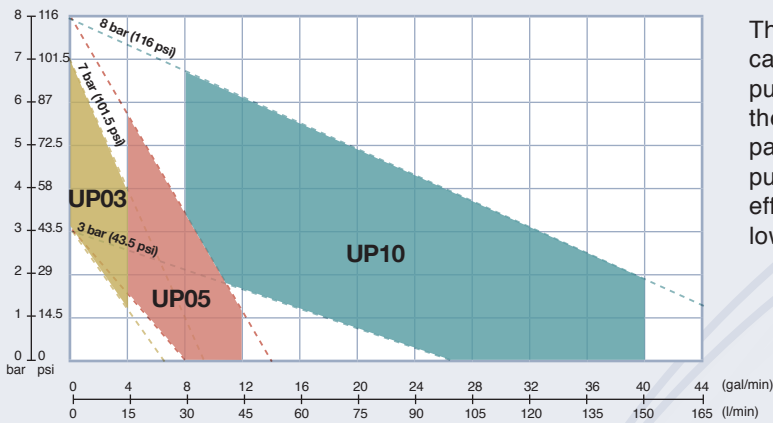

The desired flow rate and discharge pressure required can be achieved, for most applications, with different pump sizes. The optimal pump size is obtained when the expected pump working conditions are in the middle part of its Performance Chart. Selecting the larger size pump will always result in improved performance and efficiency, reduced air consumption and longer pump life lowering the overall cost of ownership.

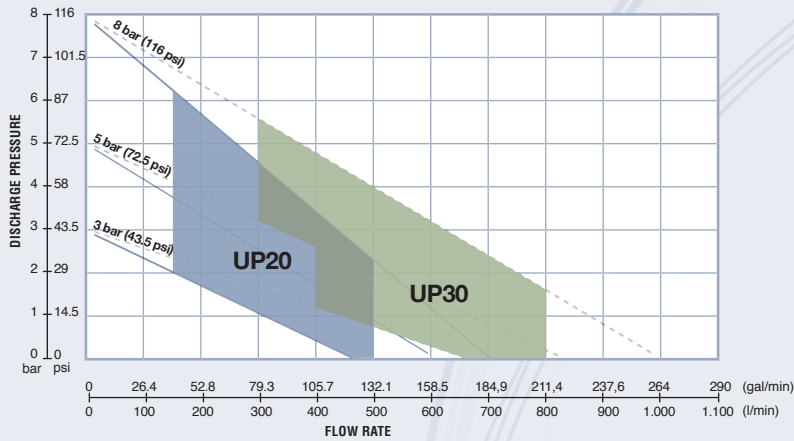
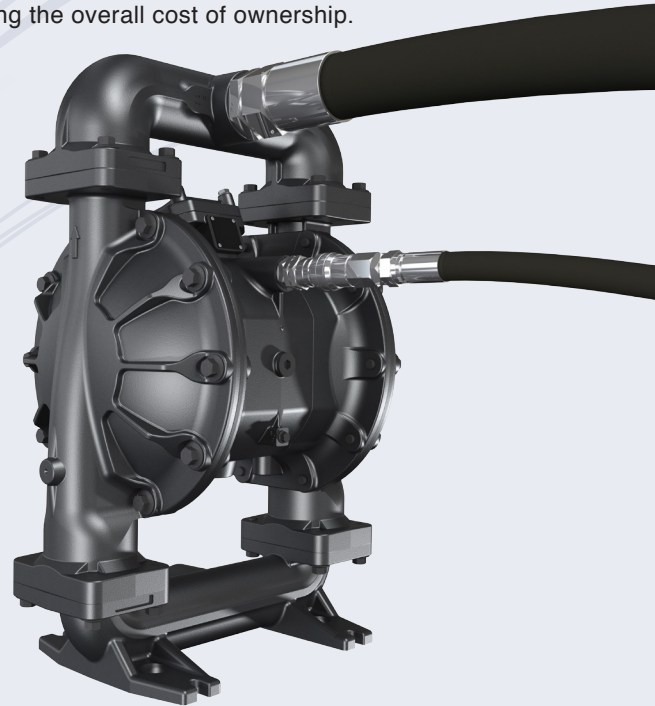

HOW TO READ A PUMP PERFORMANCE CHART

Pump performance charts provide data regarding how a particular pump performs at certain conditions. The left scale of the chart shows discharge outlet pressure. The bottom scale on the chart shows the flow rate. Performance charts also show the pump air consumption (dotted line on the chart).

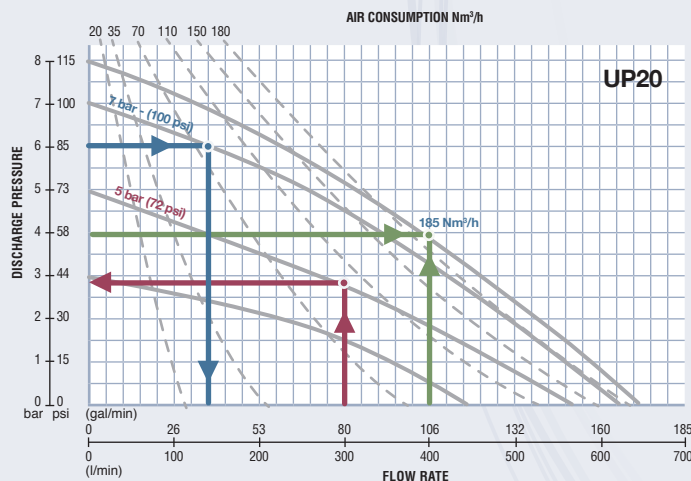
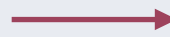

Chart obtained with water at room temperature (20 °C - 70 °F).

--- AIR CONSUMPTION
— PUMP FLOW



TO FIND THE PUMP DISCHARGE PRESSURE

1. Locate the desired flow rate along the bottom of the chart (300 l/min).
2. Follow the vertical line up to the intersection with the pump capacity curve at the fixed air inlet pressure (5 bar).
3. Follow this point left and read the pump discharge pressure (Close to 3 bar).



TO FIND THE PUMP FLOW RATE

1. Locate the desired discharge pressure drop on the left of the chart (6 bar).
2. Follow a horizontal line to the intersection with the pump capacity curve at the desired air inlet pressure (7 bar) feeding the pump.
3. Follow this point down and read the pump flow rate (140 l/min).
4. Air consumption in this case is 75 Nm³/h.

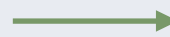

TO FIND THE AIR INLET PRESSURE AND AIR CONSUMPTION

1. Locate the desired flow rate along the bottom of the chart (400 l/min) and follow a vertical line.
2. Locate the known discharge pressure on the left of the chart (4 bar) and follow a horizontal line.
3. The intersection of these two lines determine the pump operating point. Air inlet pressure should be set at 8 bar and the air consumption would be 185 Nm³/h.

PERFORMANCE CHARTS

PUMP CAPACITY, SUCTION LIFT AND FLUID VISCOSITY.

SUCTION LIFT

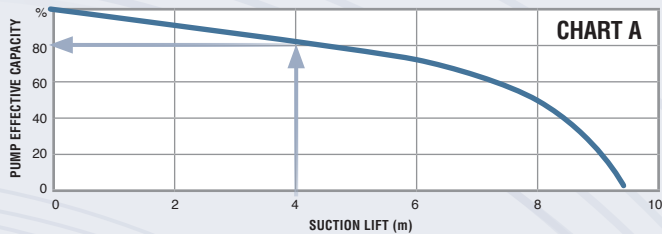

Pump capacity decreases when the suction lift increases. To find out how much the pump capacity can be reduced, use chart A.

Example:

300 l/min theoretic delivery (water) and 4 m suction lift

1. Locate the suction lift in meters along the bottom of chart A (4 m).
2. Follow a vertical line up to the intersection with the curve on the chart.
3. Follow this point to the left and read the pump effective capacity (80%).

FLOW RATE = THEORETIC FLOW RATE X EFFECTIVE CAPACITY/100

Flow rate = 300 l/min x 0,8 = 240 l/min

FLUID VISCOSITY

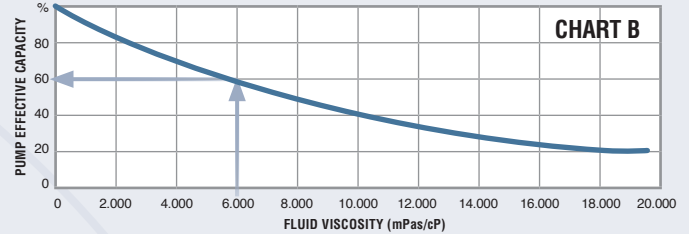

Pump capacity decreases when the fluid viscosity increases. To find out how much the pump capacity can be reduced, use chart B.

Example:

300 l/min theoretic delivery (water) and 6.000 mPas / cps fluid viscosity

1. Locate the fluid viscosity in mPas / cps along the bottom of chart B (6.000 mPas) .
2. Follow a vertical line up to the intersection with the curve on the chart.
3. Follow this point to the left and read the effective pumps capacity (60%).

FLOW RATE = THEORETIC FLOW RATE X EFFECTIVE CAPACITY/100

Flow rate = 300 l/min x 0,6 = 180 l/min

The suction lift flow restriction and the viscosity flow reduction accumulate. If you are pumping a fluid with 6000 mPas viscosity, the installation has 4 m suction lift and if the theoretic delivery (water) is 300 l/min, the real delivery would be:

FLOW RATE = THEORETIC FLOW RATE X EFFECTIVE CAPACITY DUE TO SUCTION LIFT/100 x EFFECTIVE CAPACITY DUE TO FLUID VISCOSITY/100

Flow rate = 300 l/min x 0,8 x 0,6 = 144 l/min



High suction lift reduces pump delivery.



High fluid viscosity reduces pump delivery.

AIR DISTRIBUTION SYSTEM

SAMOA Pivot Series Universal Pump (UP) combines the innovative concept of a superior Air Distribution System (Central Body, Air Covers, Air Valve and Pilot Sensors) with an enhanced Universal Air Operated Double Diaphragm Pump design.

The exclusive Air Distribution System (ADS) incorporates an innovative Pivot-Shaft together with the "Smooth-Start-Shifter" (3S) actuator (patented). It provides reliable operation, even with very reduced air pressure and / or reduced air flow.

Additionally, the ADS design prevents freezing and delivers higher and smoother flow with reduced air consumption when compared to competitive AODD Pumps. Thanks to its modular concept, SAMOA ADS is very simple to clean and to maintain.

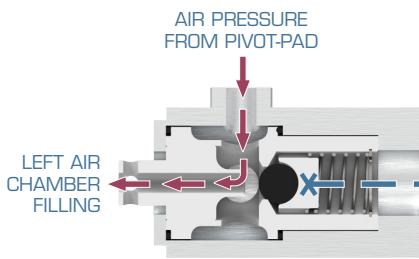

Left Pilot Sensor (closed)

Directs compressed air from the air inlet (red) towards the left air chamber, which moves the diaphragm to the Fluid Discharge Stroke.

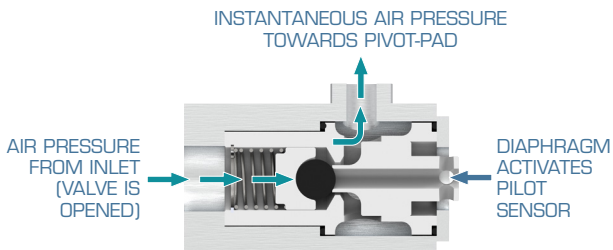

Right Pilot Sensor (open)

When the opposite diaphragm (right) has completed a Suction Stroke, it activates the pilot sensor, which sends an instant pneumatic signal to the air side Pivot-Valve pad. This changes the Pivot-Valve position, changing the pump stroke direction, filling the right chamber with air while exhausting the air from the left chamber.

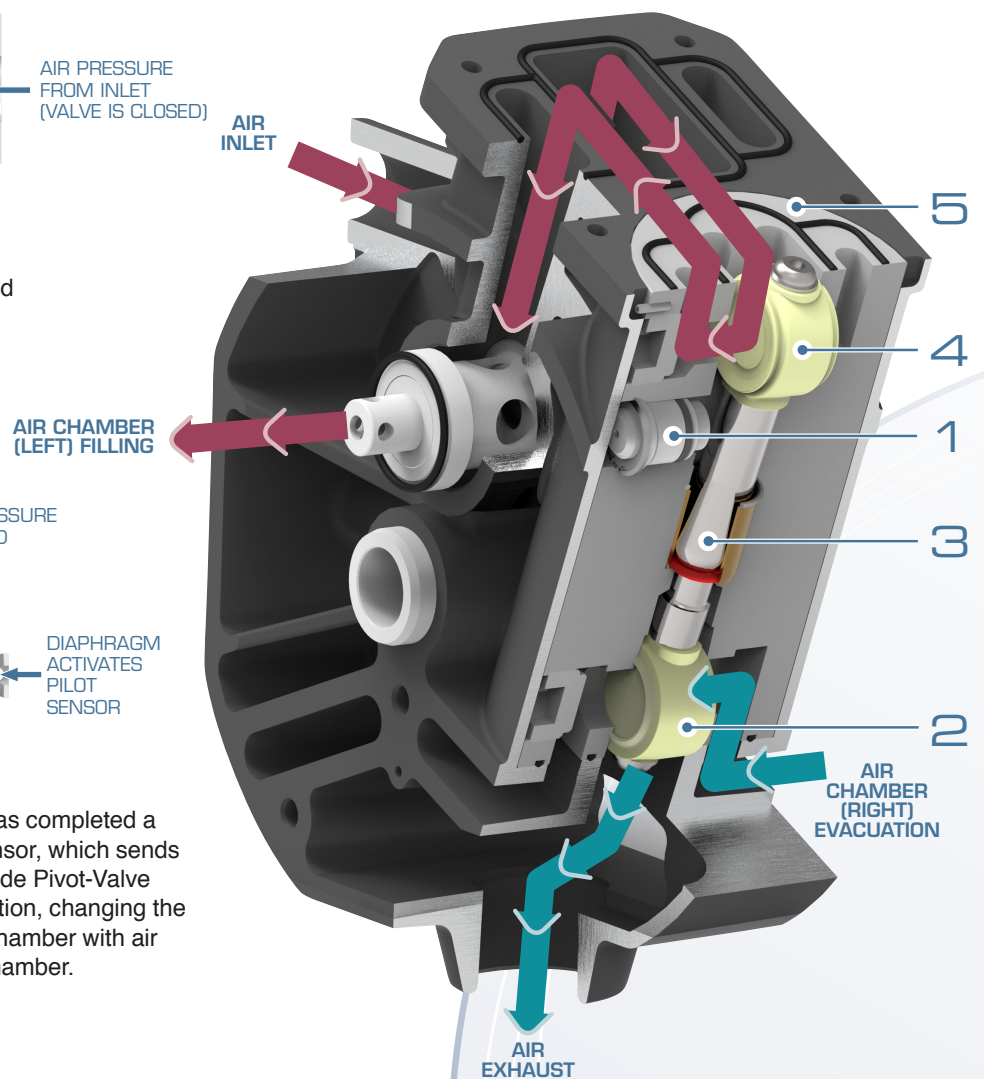
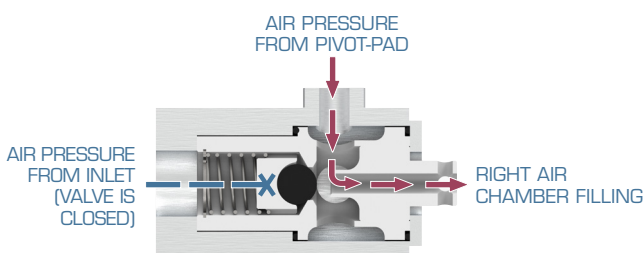

RELIABILITY, EFFICIENCY AND SIMPLICITY

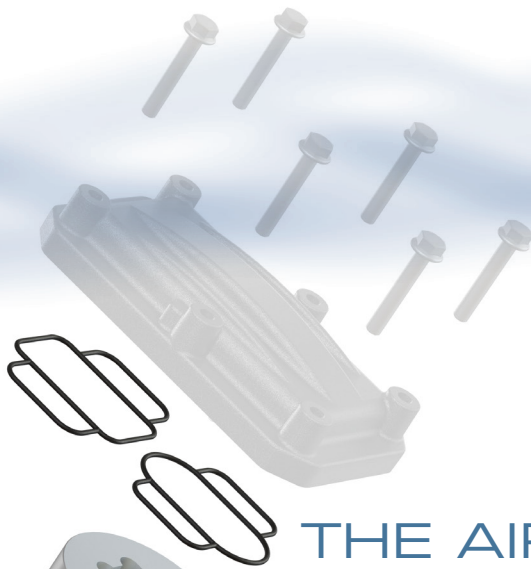

THE AIR VALVE MAKES THE DIFFERENCE

- With an innovative cartridge design, the air valve assembly can be easily removed, cleaned or replaced if necessary, reducing pump down time.
- Air valve has the fewest moving parts in the industry: no spool valves and no o-rings. Unique frictionless Pivot-Shaft Air Valve.
- Maximum reliability. Patented Smooth Start Shifter (3S) actuator activates the Pivot-Shaft for reliable operation, even with low air pressure.
- Air valve cartridge manufactured in aluminium for metal pumps and in conductive polypropylene for non-metallic pumps (except for UP05 pumps, which is always made of conductive polypropylene).

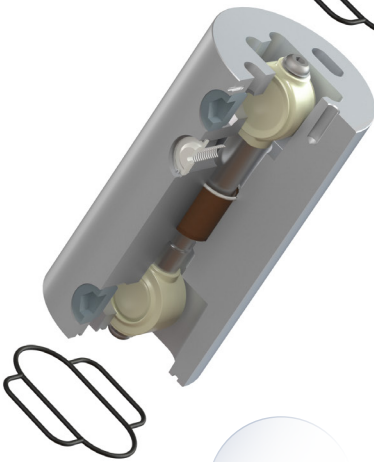

RUNS WITH DRY, DIRTY OR DAMP AIR.

LUBE-FREE OPERATION.

LONG LIFE PIVOT-PADS.



1. NO PUMP STALLING

SAMOA UP Series pumps do not stall even with low air pressure, unlike many competitive pumps. The patented “Smooth Start Shifter” (3S) actuator activates the pivot-shaft of the frictionless pivot-valve just when needed, preventing stalling.

2. NO PUMP FREEZING

Pivot Shaft exhausts the air chambers in suction stroke. Two large evacuation ports act as fast dump valves to exhaust the air from each chamber directly to the atmosphere preventing freezing and pump slowdown.

3. SMOOTH FLOW

The unique ADS, provides the fastest reciprocating action in the industry against conventional spool or sliding block valves. This contributes to provide a smoother flow and reduced vibration when compared to competitive AODD pumps.

4. EFFICIENT PUMP

The close tolerances at the ADS air inlet pivot-pad check-valves and the optimized pilot-sensors help to avoid internal air leaks, reducing air consumption and optimizing the flow versus competitors.

5. SIMPLE MAINTENANCE

The ADS used in the UP pumps has the fewest number of moving parts in the Industry. Its modular simple design reduces downtime and simplifies maintenance. The air valve module is fully accessible and can be replaced in few minutes, without removing the pump from service.

AIR MOTOR BODY SPECIFICATIONS

The pump central body encompasses air covers, air cap and the Air Distribution System (ADS) along with the Pilot Sensors, the diaphragms connecting shaft and the air pistons to form the pump air motor.

- All bolted construction: Safe-reliable-strong. Easy maintenance.
- Robust central body and air cap protect air valve by acting as a shield against accidental impact damage.
- Fully groundable for ATEX versions.
- Well dimensioned air inlet, air ducts, and pilot sensor valves eliminate pump problems caused by poor air quality and contaminants.
- Large exhaust port and high-performance muffler eliminate ice formation and reduce noise level.
- Durable and corrosion resistant diaphragms connecting shaft with male threaded ends.

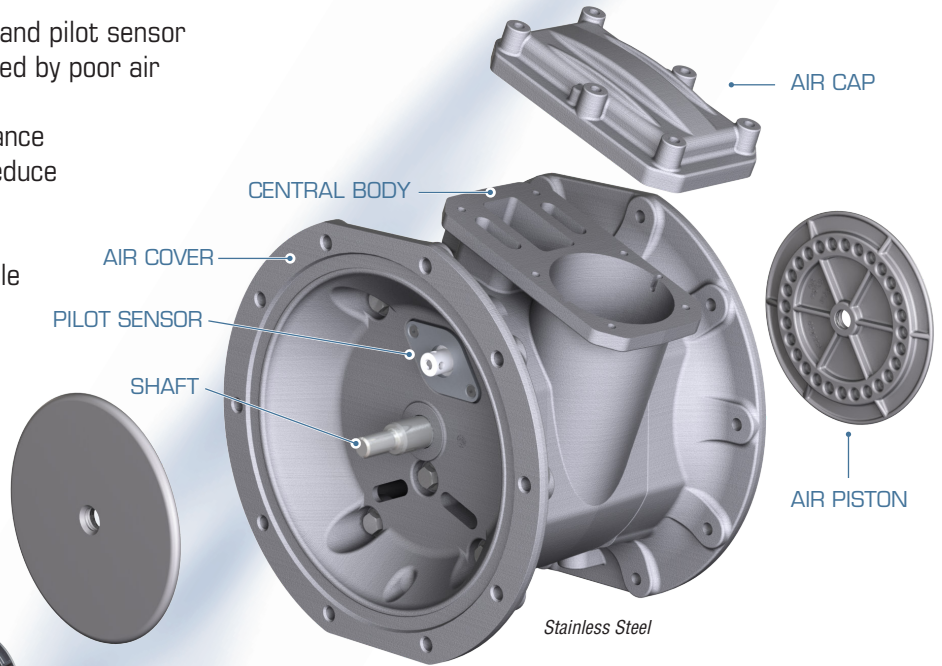

Aluminium

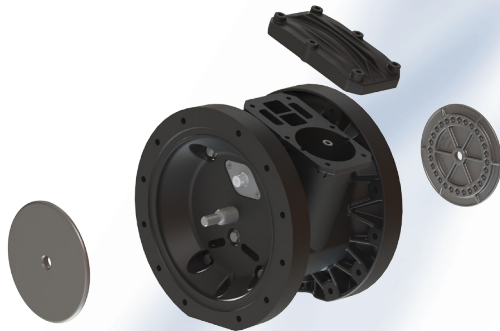

Conductive polypropylene

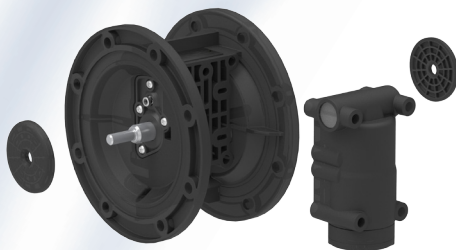

Conductive polypropylene

CENTRAL BODY, AIR COVERS, AIR CAP AND AIR PISTONS MATERIALS

ALUMINIUM

- Versatile material with good overall properties. For general purpose applications.
- External and internal Urethane Epoxy coating, UE-coat, for enhanced corrosion resistance (UP20 and UP30 pumps only).
- Used in central body, air covers, air cap and air pistons.
- Used in metallic pumps with aluminium, stainless steel or ductile iron fluid chamber covers and manifolds.

STAINLESS STEEL

- High level of corrosion resistance, mostly used in the chemical industry.
- AISI 316 Stainless steel.
- Used in air covers and air pistons combined with either aluminium or conductive polypropylene central body.
- Used in pumps with stainless steel fluid chamber covers and manifolds.

CONDUCTIVE POLYPROPYLENE

- General purpose thermoplastic material, with wide chemical compatibility.
- Can be grounded to comply with ATEX certification requirements.
- Conductive polypropylene has better mechanical properties than pure polypropylene.
- Used in central body, air covers and air cap.
- Used in pumps with polypropylene, conductive polypropylene, conductive acetal and PVDF.
- Conductive polypropylene central body, combined with stainless steel air chambers and air pistons, may be used in pumps with stainless steel fluid chamber covers and manifolds.

FLUID CHAMBERS & MANIFOLDS SPECIFICATIONS

QUICK SELECTION GUIDE

Selecting the right pump materials for your application will ensure economic operation and longer service intervals caused by failures, repairs, maintenance and pump changes.

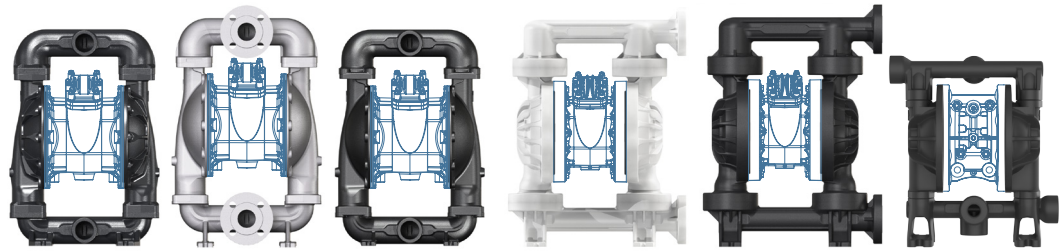

	METALLIC			NON METALLIC			
	ALUMINIUM	STAINLESS STEEL 316	DUCTILE IRON	POLYPROPYLENE NATURAL	POLYPROPYLENE CONDUCTIVE	PVDF	CONDUCTIVE ACETAL

PUMP COST PRICE	\$	\$\$\$\$	\$\$	\$\$\$	\$\$\$\$	\$\$\$\$\$\$	\$\$\$\$
------------------------	----	----------	------	--------	----------	--------------	----------

HOUSINGS & FLUID CHARACTERISTICS

	ALUMINIUM	STAINLESS STEEL 316	DUCTILE IRON	POLYPROPYLENE NATURAL	POLYPROPYLENE CONDUCTIVE	PVDF	CONDUCTIVE ACETAL
Solids in suspension	A	A	A	B	B	B	B
Large size solids non-suspended	C	C	C	D	D	D	B
Sludge/Slurry	B	B	B	C	C	C	B
Abrasive fluids. High	B	B	A	D	D	D	C
Abrasive fluids. Medium	A	B	A	C	C	C	B
Abrasive fluids. Low	A	A	A	B	B	B	A
Corrosive fluids (Chemicals)	D	B	C	A	A	A	D
Solvents (Ketones / Acetates)	B*	A	C	C	C	A	A

* Do not use with halogenated hydrocarbons.

HOUSINGS & INSTALLATION TYPE

	ALUMINIUM	STAINLESS STEEL 316	DUCTILE IRON	POLYPROPYLENE NATURAL	POLYPROPYLENE CONDUCTIVE	PVDF	CONDUCTIVE ACETAL
Flooded Suction installation	A	A	A	B	B	B	A
Suction lift installation	A	A	A	C	C	C	C
Submerged installation	B	C	A	C	C	C	C
High pressure-drop in the line	A	A	A	B	B	B	B
Fluid Containment (Bolted pump)	A	A	A	A	A	A	A

HOUSINGS & DUTY CYCLE (COMPARED TO OTHER PUMP TECHNOLOGIES)

	ALUMINIUM	STAINLESS STEEL 316	DUCTILE IRON	POLYPROPYLENE NATURAL	POLYPROPYLENE CONDUCTIVE	PVDF	CONDUCTIVE ACETAL
Intermittent/On-Demand	A	A	A	A	A	A	A
Continuous operation every day	B	B	B	B	B	B	B

A = Excellent – B= Good – C= With limitations – D= Not recommended

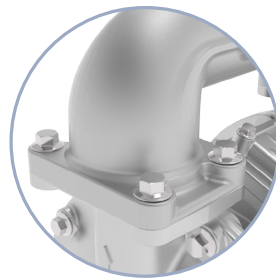
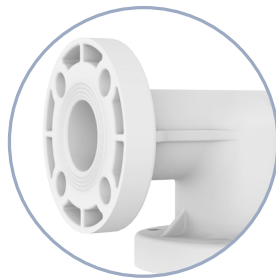
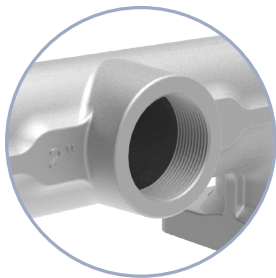

FLUID CONNECTION PORTS

Depending on the pump size and the manifolds material, fluid connection ports can be:

- BSP (parallel) or NPT (tapered) female threaded connections.
- Universal, ANSI and DIN, flange connections. Lateral flanges are off-set to keep potential leak from contaminating pump footprint.
- Non-metallic pumps with reinforced threaded connection ports, using a harder plastic material in the threaded area.

HARDWARE-BOLTS

- All bolted construction for Safety, Reliability and easy Maintenance.
- Maximum fluid containment. Uniform torque around seals and diaphragms.
- Withstands four times the pressure versus clamped pumps, preventing leakage under high pressure and dead-head conditions.
- No need to change seal after repeated maintenance services. Lower repair cost for elastomer valve seats.
- One size bolt used to fit all pump housing parts.
- Bolts available in Carbon Steel (black passivated) or Stainless Steel.

FLUID CHAMBERS SPECIFICATIONS



UP30 AISI 316
Stainless Steel



UP10 Aluminum



UP20 Ductile Iron



UP05 Polypropylene



UP03 PVDF (Polyvinylidene Fluoride)

METALLIC PUMPS

ALUMINIUM

- Versatile material with good overall properties. For general purpose applications.
- External and internal Urethane Epoxy coating, UE-coat, for enhanced corrosion resistance (UP20 and UP30 pumps only).
- Temperature range: -10 °C to +130 °C (+14 °F to +266 °F).
- Not for use with halogenated hydrocarbons.

AISI 316 STAINLESS STEEL

- High corrosion resistance, mostly used in the chemical industry. Standard die-cast surface roughness.
- High tensile resistance.
- Can be used with a wide range of chemical products.
- Temperature range: -25 °C to 130 °C (-13 °F to 266 °F).

DUCTILE IRON

- High abrasion resistance, mostly used in mining, pulp and paper industry and with abrasive materials.
- High tensile resistance.
- Temperature range: -10 °C to 130 °C (+14 °F to 266 °F).

NON-METALLIC PUMPS

POLYPROPYLENE (NATURAL OR CONDUCTIVE)

- General purpose thermoplastic, with wide chemical compatibility. Good with water soluble acids and alkalis.
- Moderate tensile resistance and flex strength.
- White colour.
- Also available as electricity conductive Polypropylene (black colour) for groundable pumps (ATEX).
- Temperature range: 0 °C to 65 °C (+32 °F to 150 °F).

CONDUCTIVE ACETAL

- Wide range of solvent resistance. Not for use with acids or alkalis.
- Good level of abrasion resistance. Withstands extreme fatigue.
- Electricity conductive material for groundable pumps (ATEX)
- Black colour.
- Temperature range: -40 °C to 120 °C (-40 °F to 250 °F)

PVDF (Polyvinylidene Fluoride) Kynar®

- A fluoroplastic, durable and with excellent chemical resistance.
- White colour.
- High tensile strength and impact resistance.
- Excellent temperature resistance.
- Temperature range: -40 °C to 121 °C (-40 °F to 250 °F).

Always check chemical compatibility of the selected materials. The pump maximum working temperature is the maximum working temperature of the lowest rated component.

FLUID MANIFOLDS SPECIFICATIONS

- Optimised fluid path and cross section for minimum internal friction.
- Bolted for enhanced safety, sealing capacity, reliability and easy assembly and disassembly.
- The discharge and inlet manifolds can be rotated 180° for accommodating their connection to inlet/discharge fluid lines.
- Designed to drop-in as a pump fit-replacement for existing systems which incorporate competitor's pumps.
- Available with either BSP or NPT female threads and DIN/ANSI flange coupling depending on pump size and materials.



UP30 Aluminium

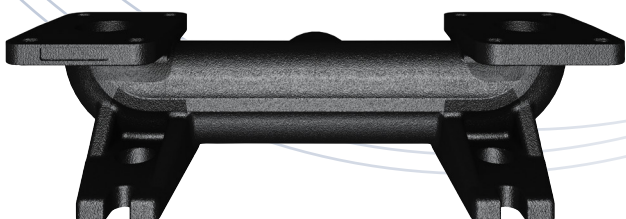

METALLIC MANIFOLDS

ALUMINIUM

- Versatile material with good overall properties. For general purpose applications.
- Suitable for abrasive slurries, adequate for use in the ceramic industry.
- External and internal Urethane Epoxy coating, UE-coat, for enhanced corrosion resistance (UP20 and UP30 pumps only).
- Not for use with halogenated hydrocarbons.

AISI 316 STAINLESS STEEL

- High corrosion resistance, mostly used in the chemical industry. Standard die-cast surface roughness.
- High tensile resistance..

DUCTILE IRON

- High abrasive resistance, mostly used in mining dewatering, pulp and paper industries and with highly abrasive materials.
- High Tensile resistance.
- External and Internal Urethane Epoxy coating, UE-coat, for enhanced corrosion resistance (UP20 and UP30 pumps only).



UP10 AISI 316 Stainless Steel



UP20 Ductile Iron



UP05 Polypropylene



UP03 PVDF (Polyvinylidene Fluoride)

NON-METALLIC MANIFOLDS

POLYPROPYLENE (NATURAL OR CONDUCTIVE)

- Wide chemical compatibility. Good with water soluble acids and caustics.
- Available as Electrically Conductive Polypropylene (black colour) for groundable pump version (ATEX).

CONDUCTIVE ACETAL

- Wide range of solvent resistance. Not for use with acids or alkalis.
- Good level of abrasion resistance. Withstands extreme fatigue.
- Electricity conductive material for groundable pumps (ATEX)
- Black color

PVDF (Polyvinylidene Fluoride) Kynar®

- A Fluoroplastic, durable and with excellent chemical resistance.
- High tensile strength and impact resistance.
- Excellent temperature resistance.

Always check chemical compatibility of the selected materials.
The pump maximum working temperature is the maximum working temperature of the lowest rated component.

CHECK-VALVES SPECIFICATIONS

WETTED PARTS SPECIFICATIONS

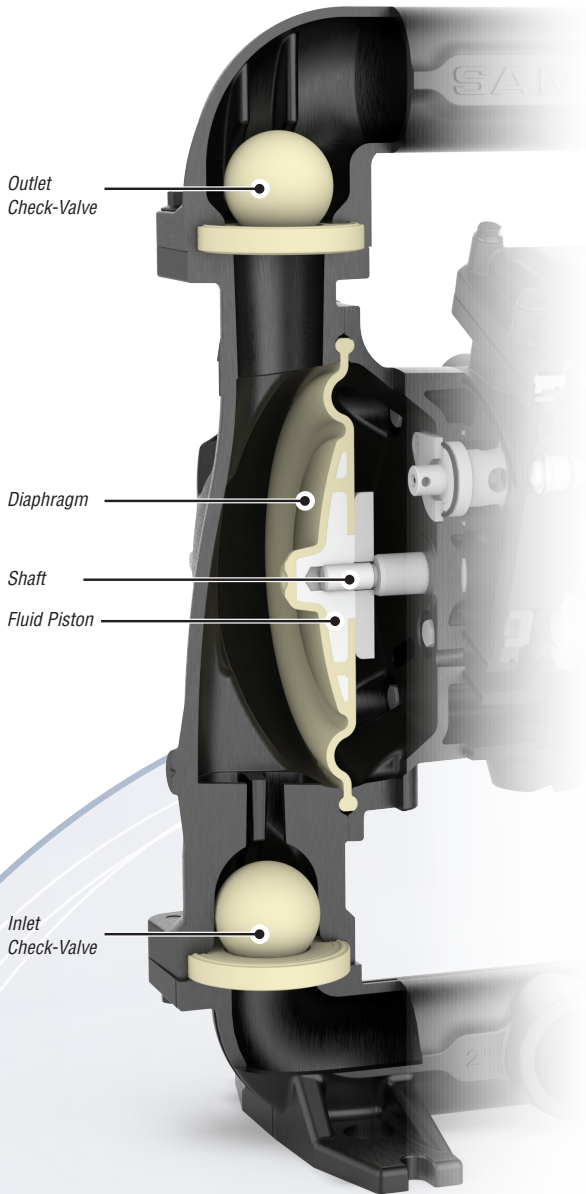

Air Operated Double Diaphragm Pumps have a very simple design with only six dynamic wetted parts: two diaphragms connected by a fluid piston with a reciprocating shaft, two inlet check-valves and two outlet check-valves. Diaphragms action forces the valve-balls to open and close on valve-seats which direct the fluid flow.

Check-valves design facilitates maintenance. Valve-seats and valve-balls can fit most pumps, within the same size, regardless the manifolds and fluid chambers material. Their modular design allows full interchangeability.

Check-valves are formed by the combination of valve-balls, valve-seats and o-rings (required with hard valve-seats). Their materials must be carefully selected to guarantee chemical compatibility with the fluid being pumped. This way problems such as swelling, cracking, or sticking do not appear and pump performance is not affected. Abrasive products can wear out the valve-seats increasing their internal diameter and ball-valves can get stuck in them. In this case, balls and seats must be replaced.

Check valve materials combination shall be selected based on:

- Maximum chemical and harsh environment resistance.
- Maximum abrasion resistance.
- Good, general purpose resistance.
- Heavier valve-balls for use with viscous products.
- Resistance to petroleum based products.
- High fluid temperature resistance.

VALVE-BALLS

- The function of the valve-balls is to open and close on the valve-seats, thus allowing fluid discharge and suction.
- The valve-balls are generally made from the same elastomeric material as the diaphragm.
- Heavy balls can also be made of Stainless Steel for use with viscous fluids.
- The valve-balls move into formed cages in the fluid chambers and the manifolds. Occasionally, due to abrasion, these cages must be inspected to evaluate excessive wear or damage.
- The balls are spherical, grinded and well balanced to guarantee a good performance and should be regularly inspected for nicks, bites, chemical attack or abrasive wear and consequently replaced if necessary.

VALVE-SEATS

- Valve seats work in conjunction with the Valve-Balls to seal the fluid inlet and outlet during pump operation.
- They can be made of elastomer and they do not require additional o-rings to seal the fluid at the cage. Elastomer valve-seats are reversible for double life.
- Hard valve-seats require additional o-rings to seal the fluid at the cage and they are not reversible.

CHECK-VALVE PARTS

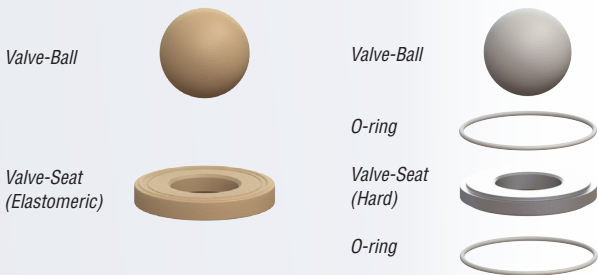

Elastomeric valve-seats do not require O-rings to seal and are reversible.

Hard valve-seats require O-rings to seal against the cage.

CHECK-VALVES MATERIALS

CHECK-VALVE MATERIAL Characteristics

Nitrile (Buna-N)	Excellent for Petroleum-based fluids.
FKM (Viton®)	Excellent for high temperature applications. Good with some aggressive fluids. High cost price.
Hytre®	Excellent for general purpose. For abrasive but non-corrosive fluids. High flex life.
Santoprene®	Good for mild acids or caustics. For abrasive fluids. For low temperatures - Best low price.
Acetal	Wide solvent compatibility. Good abrasion resistance
PTFE (Teflon®)	Excellent for highly aggressive fluids including strong solvents, hydrocarbons, acids and caustics. High cost price.
Stainless Steel 316	Excellent for highly aggressive fluids, including strong solvents, some acids and caustics. High cost price.



SEAT SELECTION

SEAT MATERIAL	Color	Cost Price	Abrasion Resist.	Acid Resist.	Caustic Resist.	Solvents (Ketones/Acetates)	Hydrocarbons (Aromatic/Chlorinated)	Petroleum Oils
Nitrile (Buna-N)*	Black	\$\$	B	D	C	C	C	A
Hytre®*	Cream	\$\$	A	C	C	B	C	A
Santoprene®*	Tan	\$	A	B	B	B	D	D
Polypropylene**	White	\$	C	A	A	B	D	D
Conductive Acetal**	Black	\$	A	D	D	A	A	A
PTFE (Teflon®)**	White	\$\$\$\$	C	A	A	A	A	A
Aluminium**	Metallic	\$\$\$	B	F	F	A	F	A
Stainless Steel 316**	Metallic	\$\$\$\$	C	B	B	A	A	A
Stainless Steel 440** Hardened (on request)	Metallic	\$\$\$\$\$	A	C	C	B	B	A

A = Excellent – B= Good – C= Fair – D= Poor – F=Not recommended.

* : Soft-type valve seats (elastomeric) do not require additional "o-rings" – Reversible design.

** : Hard-type valve seats require adequately selected "o-rings" to provide tightness between the seat and the housing. Valve seat "O-rings" available in Nitrile, EPDM, FKM (Viton®) and PTFE (Teflon®).

BALL SELECTION

BALL MATERIAL	Color	Cost Price	Abrasion Resist.	Acid Resist.	Caustic Resist.	Solvents (Ketones/Acetates)	Hydrocarbons (Aromatic/Chlorinated)	Petroleum Oils
Nitrile (Buna-N)	Black	\$\$	B	F	F	C	C	A
FKM (Viton®)	Black+Yellow	\$\$\$\$\$	B	A	A	D	A	A
Hytre®	Cream	\$\$	A	D	D	B	C	A
Santoprene®	Tan	\$\$	A	B	B	B	D	D
Acetal	White	\$	A	D	D	A	A	A
PTFE (Teflon®)	White	\$\$\$\$	C	A	A	A	A	A
Stainless Steel 316	Metallic	\$\$\$\$\$	A	B	B	A	A	A

A = Excellent – B= Good – C= Fair – D= Poor – F=Not recommended

Always check chemical compatibility of the selected materials.

DIAPHRAGMS SPECIFICATIONS

WETTED PARTS SPECIFICATIONS

EXPOSED PISTON DIAPHRAGM TYPE

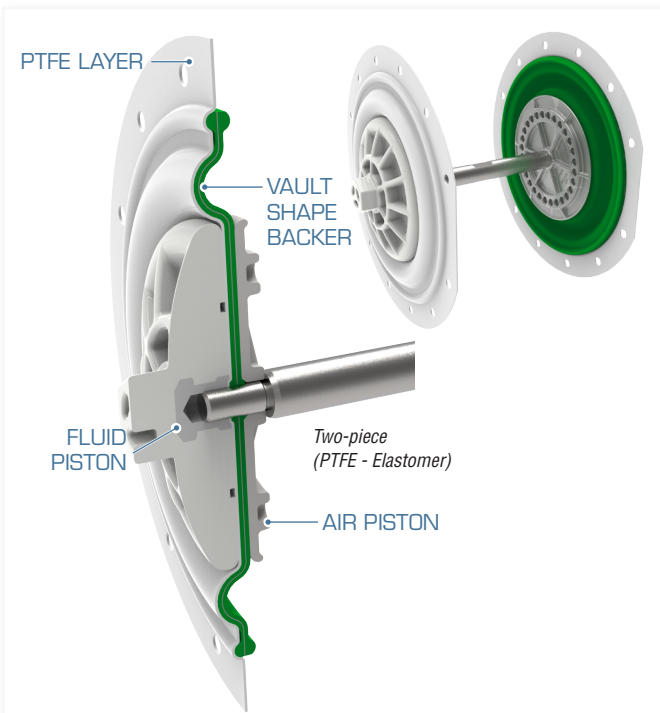

TWO-PIECE (PTFE-Elastomer) TYPE

- Laminated PTFE layer compatible with aggressive chemicals.
- PTFE layer design and material properties provide excellent flex-life.
- Annular-Vault shape design in diaphragm and Thermoplastic Elastomer backer for additional support and extended diaphragm life.
- Exposed Fluid Piston, conventional design.

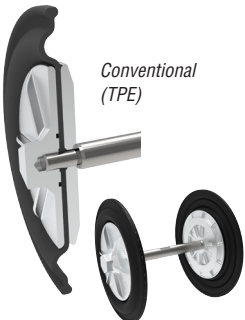

CONVENTIONAL TPE OR RUBBER DIAPHRAGM TYPE

- Annular-Vault shape design extends diaphragm life.
- Low start-up pressure.
- Exposed Fluid Piston, conventional design.
- Hytrel® and Santoprene® thermoplastic Elastomers (TPE) available.
- NBR (Buna-N) and FKM (Viton®) Rubbers available.

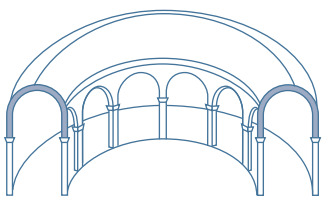

ANNULAR VAULT STRUCTURAL DESIGN

Suitable to withstand high loads if uniformly applied.

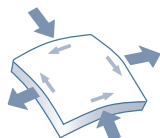

OVERMOLDED DIAPHRAGM TYPE

- Single piece diaphragms present the following advantages:
- Safety: No exposed piston to trap particles that could cause diaphragm wear. Minimum product contamination risk.
 - Clean and smooth contour, no exposed piston.
 - Durability: excellent flex life.
 - No central hole nor tight torque required. Leak free.
 - Quick, safe and easy diaphragm replacement.

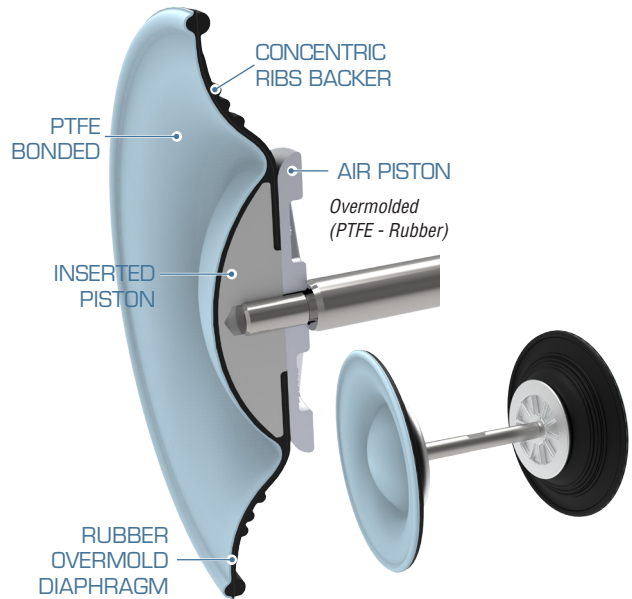

OVERMOLDED PTFE-RUBBER BONDED DIAPHRAGMS

- Inserted piston overmolded with Thermoset Rubber (EPDM).
- Dome shape design with back-up concentric ribs to give extra support with each diaphragm flexion.
- PTFE bonded layer in contact with the fluid for pumping aggressive chemicals.
- Temperature range: -10 °C to +107 °C (+14 °F to +225 °F).

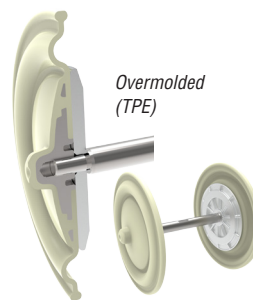

OVERMOLDED TPE DIAPHRAGMS

- Inserted Piston overmolded with Thermoplastic Elastomer (TPE).
- Annular-Vault shape design extends diaphragm life.
- Improved suction life and flow (compared to the two piece PTFE -Elastomer conventional diaphragms).
- Durability: Excellent flex life, temperature resistant.
- Available in Hytrel® and Santoprene®.

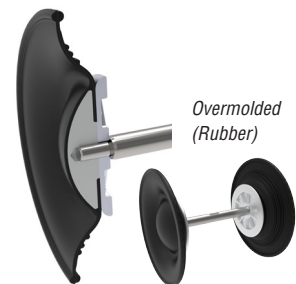

OVERMOLDED RUBBER DIAPHRAGMS

- Inserted Piston overmolded with Thermoset Rubber.
- Dome shape design with back-up concentric ribs to give extra support with each diaphragm flexion.
- Versatile, general purpose materials.
- Available in NBR (Buna-N).

DIAPHRAGM MATERIALS



ELASTOMER MATERIAL	Characteristics
Nitrile (Buna-N)	Excellent for Petroleum-based fluids.
FKM (Viton®)	Excellent for high temperature applications. Good with some aggressive fluids. High cost price.
Hytrel®	Excellent for general-purpose transfer applications. Ideal for abrasive and non-corrosive fluids. Provides excellent flex-life.
Santoprene®	Good with mild acids or caustics. Good abrasion resistance and wide chemical compatibility. Provides high flex-life. Good choice for low temperature applications. Most economic diaphragm material.
PTFE (Teflon®)	Excellent for highly aggressive fluids including strong solvents, acids, caustics. High cost price.

DIAPHRAGM SELECTION

DIAPHRAGM MATERIAL	Color	Cost Price	Flexion Resist	Abrasion Resist	Chemical Resist	Temperature Resist	Temperature Limits* °C	Temperature Limits* °F
Nitrile (Buna-N)	Black	\$\$\$	A-	B	C	C	-23°/+82°	-10°/+180°
FKM (Viton®)	Black	\$\$\$\$\$	A	C	A	A+	-40°/+177°	-40°/+350°
Hytrel®	Cream	\$\$	A	A+	C	B	-29°/+104°	-20°/+220°
Santoprene®	Tan	\$	A+	A+	B	A+	-40°/+135°	-40°/+275°
PTFE/Santoprene® (Backer)	White / Green	\$\$\$\$	C	F	A+	A	-20°/+107°	-4°/+225°
PTFE/ EPDM (Bonded)	Blue / Black	\$\$\$\$\$	B	F	A+	A+	-10°/+107°	-4°/+225°

A= Excellent, B= Good, C= Fair, D= Poor, F= Not recommended.
 (* Maximum temperature limits are based on mechanical stress resistance only. Certain chemicals can significantly reduce the maximum temperature limits.

DIAPHRAGM DESIGN

DIAPHRAGM DESIGN	FLUID TYPE					MOUNTING		REQUIRED DUTY		SERVICE
	Water	Solids charged	Abrasive	High Viscous	Common Fluid	W/Inlet Pressure	Suction Lift	Intermittent	Continuous	Maintenance
Conventional (TPE)	A	A	A	B	A	A	A	A	A	B+
Two-Piece (PTFE/Santoprene®)	A	B+	C	B	A	A	B+	A	B+	B+
Overmolded (TPE)	A+	A+	A+	A+	A+	A+	A	A+	A+	A+
Overmolded (Rubber)	A+	A	B	A+	A+	A+	A+	A+	A+	A+
Overmolded (PTFE/ EPDM)	A+	A+	C+	A+	A+	A+	A	A+	A+	A+

A= Excellent, B= Good, C= Fair.
 Please note that excessive inlet pressure or excessive suction lift can shorten diaphragm life.

Always check chemical compatibility of the selected materials.

UPO3 SERIES

3/8" NON-METALLIC PUMPS

The 3/8" (9,5 mm) Air Operated Diaphragm Pumps made of injected moulded plastic parts can reach a flow rate up to 31 l/min (8,2 gal/min). They are available in Natural or Conductive Polypropylene, PVDF or Conductive Acetal for optimum fluid compatibility.

Pumps are designed with side off-set threaded inlet and outlet ports, to avoid any material leaks onto the pump. Manifolds can rotate 180° for maximum installation versatility. Additional central inlet port facing downwards gives the possibility to connect a suction tube directly to the pump.

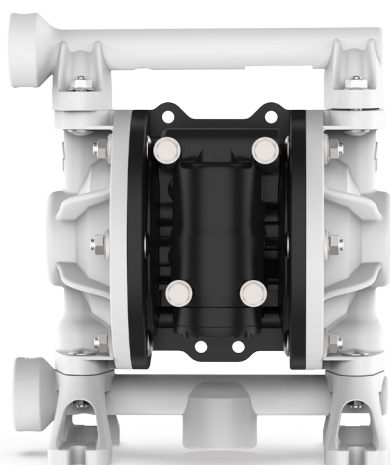

Polypropylene version

Non contractual pictures.

PUMP NOMENCLATURE

Examples: **UPO3B-XXX-XXX**
UE03B-XXX-XXX-X

MAIN APPLICATIONS

- OIL & GAS, PETROCHEMICAL
- PULP & PAPER
- CHEMICAL PLANT PROCESSING
- PAINTS & COATINGS
- TEXTILES, LEATHERS & GARMENTS
- PLANT AND MECHANICAL ENGINEERING
- WASTEWATER & WATER TREATMENT
- MARINE
- ENERGY
- ELECTRONICS

TECHNICAL DATA

UPO3 NON-METALLIC PUMPS

Pressure Ratio	1:1
Maximum Free Delivery	31 l/min (8,2 US gal/min)
Air pressure range	1,5 to 7 bar (20 to 100 psi)
Solids in suspension, Max. size	1,6 mm (1/16")
Max dry suction lift	3 m (10')
Max wet suction lift	7 m (23')
Displacement per cycle*	0,08 l (0,02 gal)
Fluid inlet/outlet ports (Female)	3/8" NPT (F) Threaded 3/8" BSP (F) Threaded
Air Inlet Port (Female)	1/4" NPSM (F)
Air Exhaust Port (Female)	1/2" NPT (F)
Sound level	75 dB (A) @50 cycles/min @70 psi
Weight	
Polypropylene pump	1,8 kg (4 lb)
Conductive Polypropylene pump	2 kg (4.4 lb)
PVDF pump	2,3 kg (5.1 lb)
Conductive Acetal pump	2,1 kg (4.6 lb)

* Delivery per cycle depends on the diaphragms material, air inlet pressure and fluid viscosity.

UPO3B		XXX			XXX			X
PUMP TYPE		AIR MOTOR	HOUSINGS		WETTED PARTS			ACCESSORIES
1 Pump Type & Size	2 Central Body & Air Chambers	3 Fluid Ports / Location Multiport manifolds: central and lateral	4 Fluid Chambers & Manifolds	5 Hardware Bolts & Inserts	6 Valve Seats	7 Valve Balls	8 Diaphragms Type & Material	9 Accessories (UE pumps only)
UPO3 Universal Pump (Bolted) UE03 Universal Pump (Bolted) with electronic interface	ATEX Certified B* = Conductive Polypropylene (black)	B = 3/8" BSP threaded ports N = 3/8" NPT threaded ports	P = Polypropylene (white) W = PVDF (Kynar®) (white) <hr/> ATEX Certified B* = Conductive Polypropylene (black) C* = Conductive Acetal (black)	S = Stainless Steel	C = Acetal P = Polypropylene T = PTFE (Teflon®)	C = Acetal T = PTFE (Teflon®)	A = Santoprene® C = Hytrel® G = Nitrile (Buna-N) Two piece Z = PTFE (Teflon® with Santoprene® backer)	A = Diaphragm leak detectors B = Diaphragm leak detectors (ATEX) C = Stroke sensor (PLC) D = Stroke sensor (ATEX) E = Stroke sensor (ATEX) F = Diaphragm leak detectors + Stroke sensor G = Diaphragm leak detectors + Stroke sensor (PLC) H = Diaphragm leak detectors + Stroke sensor (ATEX)

* **ATEX Certified pumps** for use in hazardous locations ATEX Group II 2GDx.

Hytrel® is a registered trademark of the DuPont Company, Vitor® & Teflon® of the Chemours Company and Santoprene® of the Monsanto Company, licensed for Advanced Elastomer Systems, L.P. Kynar® is a registered trademark of Arkema, Inc.

3/8" (9,5 mm) NON-METALLIC PUMPS: DIMENSIONS AND PERFORMANCE CHARTS

UP03 NON-METALLIC PUMPS

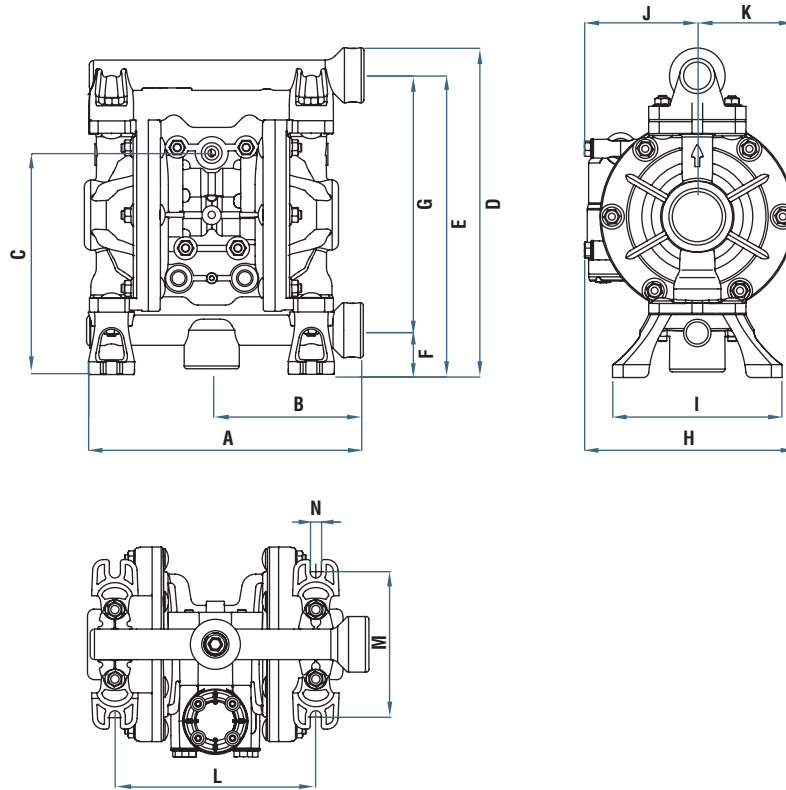

DIMENSIONS (mm)

UP03 PUMP

	A	B	C	D	E	F	G	H	I	J	K	L	M	N
UP03 PUMP	202	110	161	237	217	32	185	151	122	81	70	145	104	8

DIMENSIONS (inches)

UP03 PUMP

	A	B	C	D	E	F	G	H	I	J	K	L	M	N
UP03 PUMP	7 61/64	4 21/64	6 11/32	9 21/64	7 7/8	2 1/64	8 7/64	5 15/16	4 51/64	3 3/16	2 3/4	5 45/64	4 3/32	0 5/16

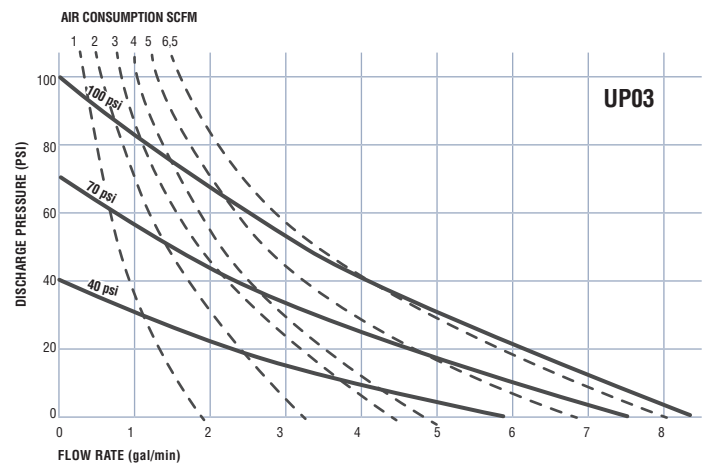
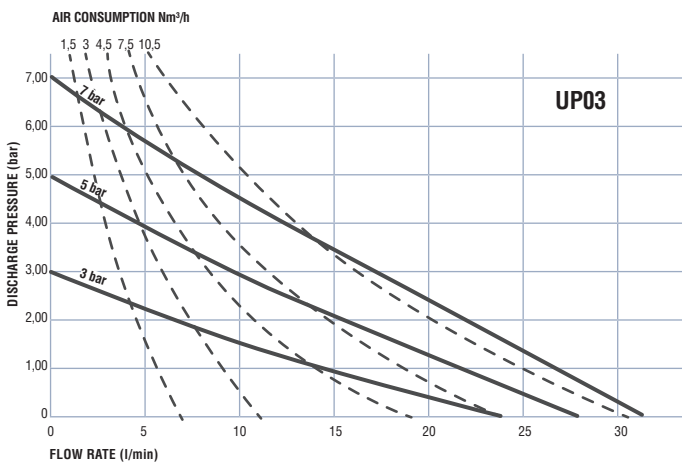

Performance charts with water at room temperature (20 °C - 70 °F)

UPO5 SERIES

1/2" NON-METALLIC PUMPS

The 1/2" (13 mm) Air Operated Diaphragm Pumps made of injected moulded plastic parts can reach a flow rate up to 51 l/min (13,5 gal/min). They are available in Natural or Conductive Polypropylene, PVDF or Conductive Acetal for optimum fluid compatibility.

Multiple threaded discharge and outlet port options provide maximum installation versatility. Manifolds can rotate 180° for more installation options and an inlet port looking downwards give the possibility of connecting a suction tube directly to the pump.

MAIN APPLICATIONS

- OIL & GAS/PETROCHEMICAL
- MINING & CONSTRUCTION
- PULP & PAPER
- CHEMICAL PLANT PROCESSING
- PAINTS & COATINGS
- TEXTILES, LEATHERS & GARMENTS
- PLANT AND MECHANICAL ENGINEERING
- WASTEWATER & WATER TREATMENT
- MARINE
- ENERGY
- ELECTRONICS

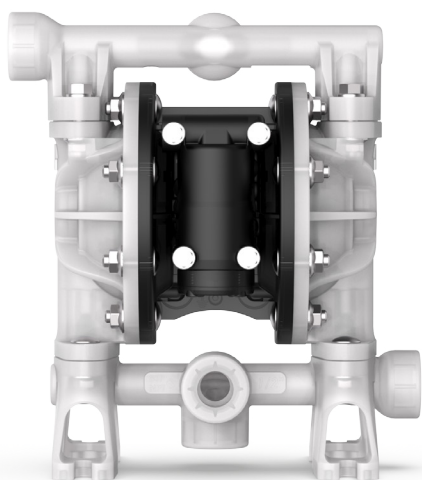

Polypropylene version

Non contractual pictures.

PUMP NOMENCLATURE

Examples: **UP05B-XXX-XXX**
UE05B-XXX-XXX-X

TECHNICAL DATA

UPO5 NON-METALLIC PUMPS

Pressure Ratio	1:1
Maximum Free Delivery	51 l/min (13,5 US gal/min)
Air pressure range	1,5 to 7 bar (20 to 100 psi)
Solids in suspension, Max. size	2,5 mm (3/32")
Max dry suction lift	5 m (16")
Max wet suction lift	8 m (26")
Displacement per cycle*	0,15 l (0,04 gal)
Fluid inlet/outlet ports (Female)	1/2" NPT (F) Threaded 1/2" BSP (F) Threaded
Air Inlet Port (Female)	1/4" NPSM (F)
Air Exhaust Port (Female)	1/2" NPT (F)
Sound level	75 dB (A) @50 cycles/min@70 psi
Weight	
Polypropylene pump	2,7 kg (6 lb)
Conductive Polypropylene pump	3 kg (6.6 lb)
PVDF pump	3,7 kg (8.2 lb)
Conductive Acetal pump	3,3 kg (7.3 lb)

* Delivery per cycle depends on the diaphragms material, air inlet pressure and fluid viscosity.

UPO5B		XXX			XXX			X
PUMP TYPE	AIR MOTOR	HOUSINGS			WETTED PARTS			ACCESSORIES
1 Pump Type & Size	2 Central Body & Air Chambers	3 Fluid Ports / Location Multiport manifolds: central and lateral	4 Fluid Chambers & Manifolds	5 Hardware Bolts & Inserts	6 Valve Seats	7 Valve Balls	8 Diaphragms Type & Material	9 Accessories (UE pumps only)
UP05 Universal Pump (Bolted) UE05 Universal Pump (Bolted) with electronic interface	ATEX Certified B* = Conductive Polypropylene (black)	B = 1/2" BSP threaded ports N = 1/2" NPT threaded ports	P = Polypropylene (white) W = PVDF (Kynar®) (white) <hr/> ATEX Certified B* = Conductive Polypropylene (black) D* = Conductive Acetal (black)	S = Stainless Steel	C = Acetal P = Polypropylene S = AISI 316 Stainless Steel T = PTFE (Teflon®) V = FKM (Viton®)	H = Hytrel® M = Santoprene® N = Nitrile (Buna-N) S = AISI 316 Stainless Steel T = PTFE (Teflon®) V = FKM (Viton®)	A = Santoprene® C = Hytrel® G = Nitrile (Buna-N) V = FKM (Viton®) Two piece Z = PTFE (Teflon® with Santoprene® backer)	A = Diaphragm leak detectors B = Diaphragm leak detectors (ATEX) C = Stroke sensor D = Stroke sensor (PLC) E = Stroke sensor (ATEX) F = Diaphragm leak detectors + Stroke sensor G = Diaphragm leak detectors + Stroke sensor (PLC) H = Diaphragm leak detectors + Stroke sensor (ATEX)

* **ATEX Certified pumps** for use in hazardous locations ATEX Group II 2GDx.

Hytrel® is a registered trademark of the DuPont Company, Viton® & Teflon® of the Chemours Company and Santoprene® of the Monsanto Company, licensed for Advanced Elastomer Systems, L.P. Kynar® is a registered trademark of Arkema, Inc.

1/2" (13 mm) NON-METALLIC PUMPS: DIMENSIONS AND PERFORMANCE CHARTS

UP05 NON-METALLIC PUMPS

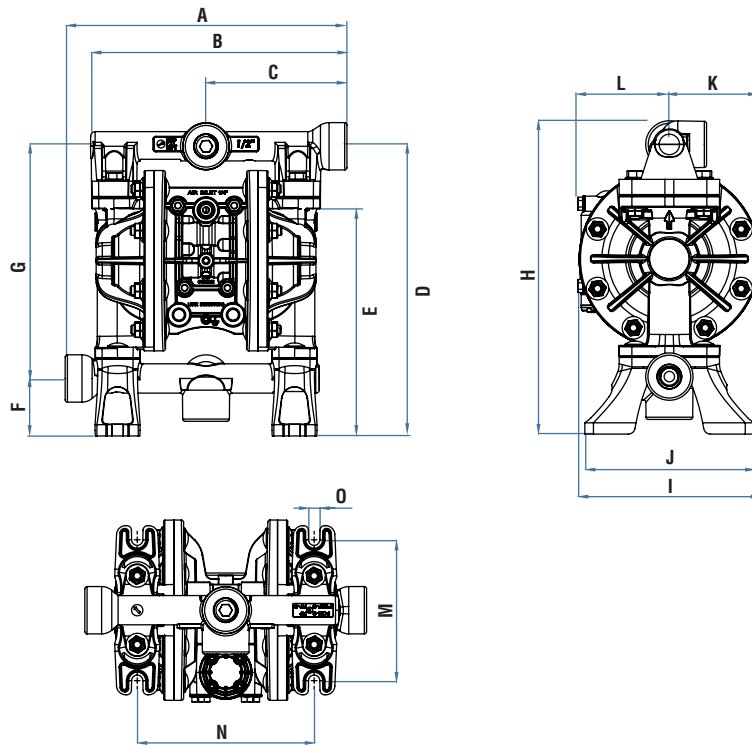

DIMENSIONS (mm)	A	B	C	D	E	F	G	H	I	J	K	L	M	N	O
UP05 PUMP	250	228	125	257	200	51	206	278	161	150	80	81	125	157	10

DIMENSIONS (inches)	A	B	C	D	E	F	G	H	I	J	K	L	M	N	O
UP05 PUMP	9 27/32	8 61/64	4 59/64	10 1/8	7 7/8	2 1/64	8 7/64	10 15/16	6 11/32	5 29/32	3 5/32	3 3/16	4 59/64	6 3/16	0 25/64

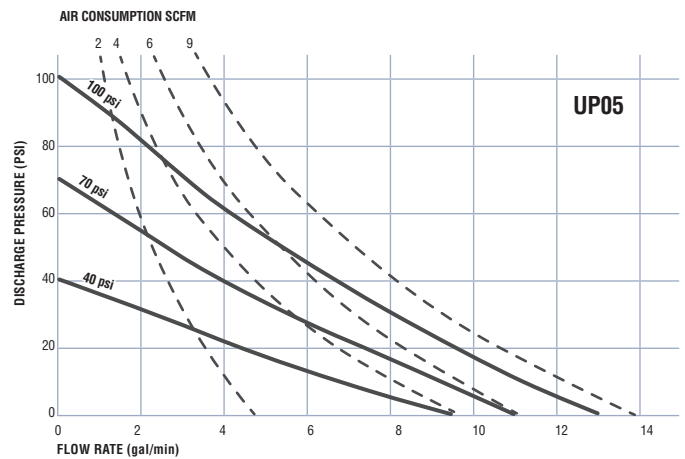
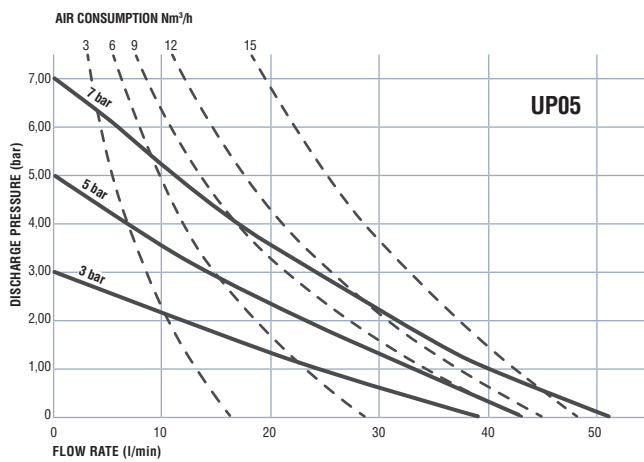

Performance charts with water at room temperature (20 °C - 70 °F)

UPO5 SERIES

1/2" METALLIC PUMPS

The 1/2" (13 mm) Air Operated Diaphragm Pumps made of cast metal parts can reach a flow rate up to 54 l/min (14,3 gal/min). They are available in Aluminium and AISI 316 Stainless Steel for optimum fluid compatibility.

Aluminium pumps are available with lateral off-set threaded inlet and outlet ports. Stainless steel pumps have central threaded inlet and outlet ports. Can rotate 180° for more installation options and an inlet port looking downwards give the possibility of connecting a suction tube directly to the pump.

MAIN APPLICATIONS

- OIL & GAS/PETROCHEMICAL
- MINING & CONSTRUCTION
- PULP & PAPER
- CHEMICAL PLANT PROCESSING
- PAINTS & COATINGS
- TEXTILES, LEATHERS & GARMENTS
- PLANT AND MECHANICAL ENGINEERING
- WASTEWATER & WATER TREATMENT
- MARINE
- ENERGY
- ELECTRONICS



Stainless Steel version

Aluminium version

Non contractual pictures.

PUMP NOMENCLATURE

Examples: **UP05X-XXX-XXX**
UE05X-XXX-XXX-X

TECHNICAL DATA

UPO5 METALLIC PUMPS

Pressure Ratio	1:1
Maximum Free Delivery	54 l/min (14,3 US gal/min)
Air pressure range	1,5 to 8 bar (20 to 120 psi)
Solids in suspension, Max. size	2,5 mm (3/32")
Max dry suction lift	5 m (16")
Max wet suction lift	8 m (26")
Displacement per cycle*	0,15 l (0,04 gal)
Fluid inlet/outlet ports (Female)	1/2" NPT (F) Threaded 1/2" BSP (F) Threaded
Air Inlet Port (Female)	1/4" NPSM (F)
Air Exhaust Port (Female)	1/2" NPT (F)
Sound level	75 dB (A) @50 cycles/min@70 psi
Weight	
Aluminium pump	3,9 kg (8,6 lb)
Stainless steel pump	6,5 kg (14,3 lb)

* Delivery per cycle depends on the diaphragms material, air inlet pressure and fluid viscosity.

UP05X		XXX			XXX			X
PUMP TYPE	AIR MOTOR	HOUSINGS			WETTED PARTS			ACCESSORIES
1 Pump Type & Size	2 Central Body & Air Chambers	3 Fluid Ports / Location Multiport manifolds: central and lateral	4 Fluid Chambers & Manifolds	5 Hardware Bolts	6 Valve Seats	7 Valve Balls	8 Diaphragms Type & Material	9 Accessories (UE pumps only)
UP05 Universal Pump (Bolted) UE05 Universal Pump (Bolted) with electronic interface	ATEX Certified A* = Aluminium B* = Conductive Polypropylene (black)	B = 1/2" BSP threaded ports N = 1/2" NPT threaded ports	ATEX Certified A* = Aluminium S* = AISI 316 Stainless Steel	C = Carbon Steel S = Stainless Steel	A = Aluminium S = AISI 316 Stainless Steel V = FKM (Viton®)	H = Hytrel® M = Santoprene® N = Nitrile (Buna-N) S = AISI 316 Stainless Steel T = PTFE (Teflon®) V = FKM (Viton®)	A = Santoprene® C = Hytrel® G = Nitrile (Buna-N) V = FKM (Viton®) Two piece Z = PTFE (Teflon® with Santoprene® backer)	A = Diaphragm leak detectors B = Diaphragm leak detectors (ATEX) C = Stroke sensor D = Stroke sensor (PLC) E = Stroke sensor (ATEX) F = Diaphragm leak detectors + Stroke sensor G = Diaphragm leak detectors + Stroke sensor (PLC) H = Diaphragm leak detectors + Stroke sensor (ATEX)

* **ATEX Certified pumps** for use in hazardous locations ATEX Group II 2GDx.

Hytrel® is a registered trademark of the DuPont Company, Viton® & Teflon® of the Chemours Company and Santoprene® of the Monsanto Company, licensed for Advanced Elastomer Systems, L.P. Kynar® is a registered trademark of Arkema, Inc.

1/2" (13 mm) METALLIC PUMPS: DIMENSIONS AND PERFORMANCE CHARTS

UP05 ALUMINIUM THREADED PUMPS

UP05 STAINLESS STEEL THREADED PUMPS

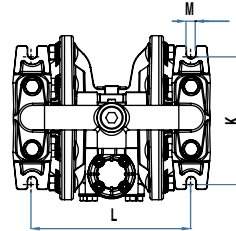
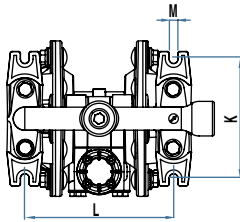
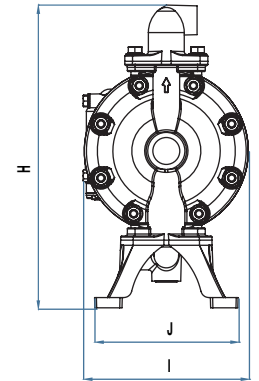
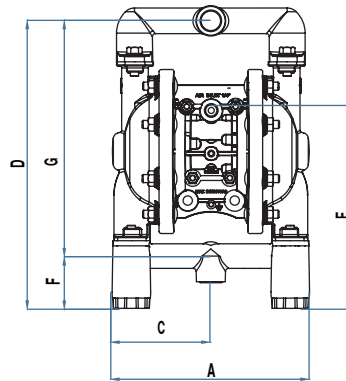
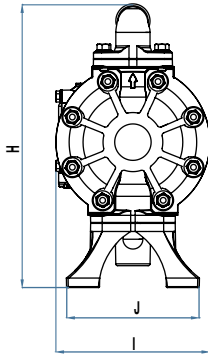
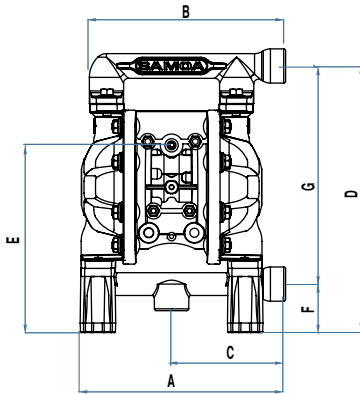

DIMENSIONS (mm)

UP05 ALUMINIUM

UP05 STAINLESS STEEL PUMP

A	B	C	D	E	F	G	H	I	J	K	L	M
216	207	120	281	197	51	230	299	162	140	124	155	9
193	-	96	281	198	51	230	295	161	140	124	155	9

DIMENSIONS (inches)

UP05 ALUMINIUM

UP05 STAINLESS STEEL PUMP

A	B	C	D	E	F	G	H	I	J	K	L	M
8 1/2	8 5/32	4 23/32	11 1/16	7 3/4	2 1/64	9 1/16	11 49/64	6 3/8	5 33/64	4 7/8	6 7/64	0 23/64
7 19/32	-	3 25/32	11 1/16	7 51/64	2 1/64	9 1/16	11 39/64	6 11/32	5 33/64	4 7/8	6 7/64	0 23/64

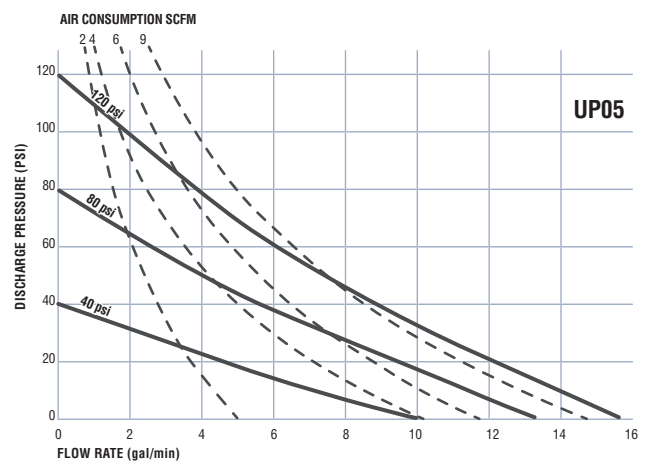
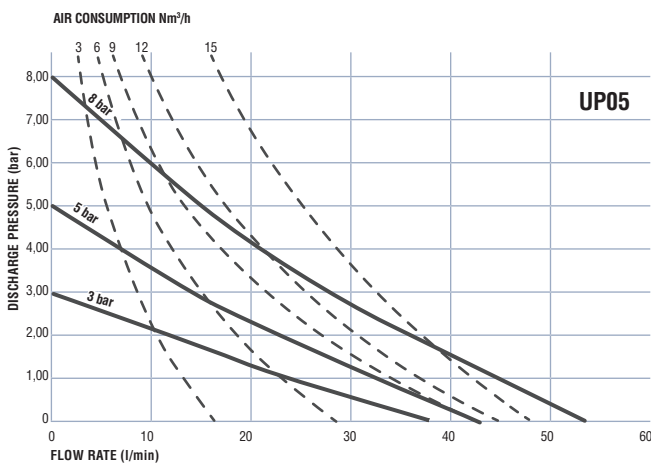

Performance charts with water at room temperature (20 °C - 70 °F)

UP10 SERIES

1" NON-METALLIC PUMPS

The 1" (25 mm) Air Operated Diaphragm Pumps made of injected moulded plastic parts can reach a flow rate up to 200 l/min (52 gal/min). They are available in Natural or Conductive Polypropylene and PVDF for optimum fluid compatibility.

Pumps are available with either side off-set or central flanged or threaded inlet and outlet ports. Manifolds can rotate 180° for maximum pump installation versatility.

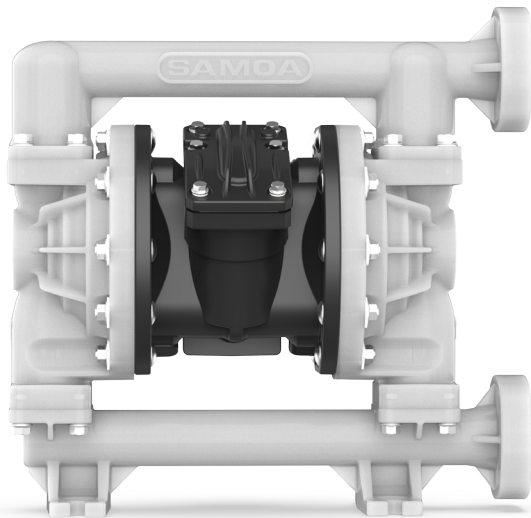

Polypropylene version

Non contractual pictures.

PUMP NOMENCLATURE

Examples: **UP10B-XXX-XXX**
UE10B-XXX-XXX-X

UP10B		XXX			XXX			X
PUMP TYPE	AIR MOTOR	HOUSINGS		WETTED PARTS			ACCESSORIES	
1 Pump Type & Size	2 Central Body & Air Chambers	3 Fluid Ports / Location Multiport manifolds: central or lateral	4 Fluid Chambers & Manifolds	5 Hardware Bolts & Inserts	6 Valve Seats	7 Valve Balls	8 Diaphragms Type & Material	9 Accessories (UE pumps only)
UP10 Universal Pump (Bolted) UE10 Universal Pump (Bolted) with electronic interface	ATEX Certified B* = Conductive Polypropylene (black)	Central ports C = 1" ANSI/DIN flanged ports B = 1" BSP threaded ports N = 1" NPT threaded ports Lateral ports F = 1" ANSI/DIN flanged ports P = 1" BSP threaded ports T = 1" NPT threaded ports	P = Polypropylene (white) W = PVDF (Kynar®) (white) ATEX Certified B* = Conductive Polypropylene (black)	S = Stainless Steel	P = Polypropylene T = PTFE (Teflon®) V = FKM (Viton®)	H = Hytrel® M = Santoprene® N = Nitrile (Buna-N) T = PTFE (Teflon®) V = FKM (Viton®)	A = Santoprene® C = Hytrel® G = Nitrile (Buna-N) V = FKM (Viton®) Two piece Z = PTFE (Teflon® with Santoprene® backer)	A = Diaphragm leak detectors B = Diaphragm leak detectors (ATEX) C = Stroke sensor D = Stroke sensor (PLC) E = Stroke sensor (ATEX) F = Diaphragm leak detectors + Stroke sensor G = Diaphragm leak detectors + Stroke sensor (PLC) H = Diaphragm leak detectors + Stroke sensor (ATEX)

* **ATEX Certified pumps** for use in hazardous locations ATEX Group II 2GDx.

Hytrel® is a registered trademark of the DuPont Company, Viton® & Teflon® of the Chemours Company and Santoprene® of the Monsanto Company, licensed for Advanced Elastomer Systems, L.P. Kynar® is a registered trademark of Arkema, Inc.

MAIN APPLICATIONS

- OIL & GAS/PETROCHEMICAL
- MINING & CONSTRUCTION
- PULP & PAPER
- CHEMICAL PLANT PROCESSING
- PAINTS & COATINGS
- TEXTILES, LEATHERS & GARMENTS
- PLANT AND MECHANICAL ENGINEERING
- WASTEWATER & WATER TREATMENT
- MARINE
- CERAMICS
- ENERGY
- ELECTRONICS

TECHNICAL DATA

UP10 NON-METALLIC PUMPS

Pressure Ratio	1:1	
Maximum Free Delivery	200 l/min (53 US gal/min)	
Air pressure range	1,5 to 7 bar (20 to 100 psi)	
Solids in suspension, Max. size	6,4 mm (1/4")	
Max dry suction lift	5 m (16')	
Max wet suction lift	8 m (26')	
Displacement per cycle*	0,85 l (0,2 gal)	
Fluid inlet/outlet ports (Female)	1" BSP or NPT (F) Threaded FLANGE DIN DN25 / ANSI 1"	
Air Inlet Port (Female)	1/2" NPSM (F)	
Air Exhaust Port (Female)	1" NPT (F)	
Sound level	75 dB (A) @50 cycles/min @70 psi	
Weight	Threaded	Flanged
Polypropylene pump	10,2 kg (22,5 lb)	10,5 kg (23,1 lb)
Conductive Polypropylene pump	11,6 kg (25,6 lb)	12 kg (26,4 lb)
PVDF pump	13,5 kg (29,8 lb)	14,1 kg (31,1 lb)

* Delivery per cycle depends on the diaphragms material, air inlet pressure and fluid viscosity.

1" (25 mm) NON-METALLIC PUMPS: DIMENSIONS AND PERFORMANCE CHARTS

UP10 NON-METALLIC LATERAL PORTS PUMPS

UP10 NON-METALLIC CENTRAL PORTS PUMPS

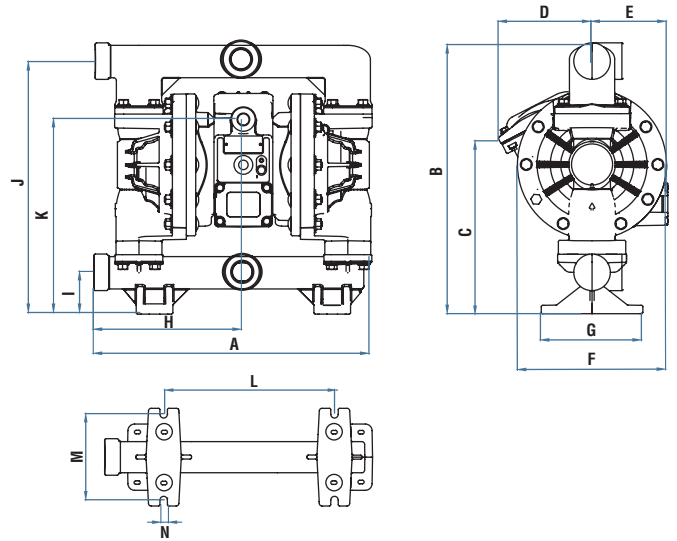
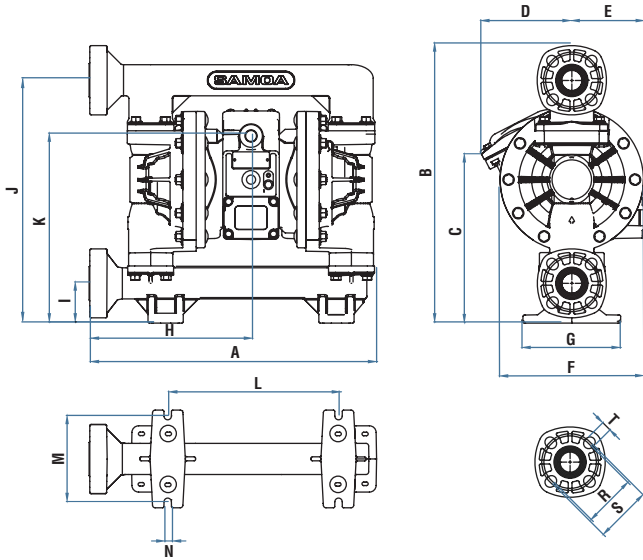

DIMENSIONS (mm)

UP10 LATERAL-FLANGED PUMP
 UP10 CENTRAL-FLANGED PUMP
 UP10 LATERAL-THREADED PUMP
 UP10 CENTRAL-THREADED PUMP

	A	B	C	D	E	F	G	H	I	J	K	L	M	N	R	S	T
UP10 LATERAL-FLANGED PUMP	425	415	250	135	108	214	146	241	59	363	280	255	128	11	77,5	83,5	15
UP10 CENTRAL-FLANGED PUMP	399							56									
UP10 LATERAL-THREADED PUMP	399	386	250	135	108	214	146	211	59	363	280	255	128	11			
UP10 CENTRAL-THREADED PUMP								40									

DIMENSIONS (inches)

UP10 LATERAL-FLANGED PUMP
 UP10 CENTRAL-FLANGED PUMP
 UP10 LATERAL-THREADED PUMP
 UP10 CENTRAL-THREADED PUMP

	A	B	C	D	E	F	G	H	I	J	K	L	M	N	R	S	T
UP10 LATERAL-FLANGED PUMP	16 47/64	16 11/32	9 27/32	5 5/16	4 1/4	8 27/64	5 3/4	9 31/64	2 21/64	14 19/64	11 1/32	10 3/64	5 3/64	7/16	3 3/64	3 9/32	19/32
UP10 CENTRAL-FLANGED PUMP	15 45/64							2 13/64									
UP10 LATERAL-THREADED PUMP	15 45/34	15 13/64	9 27/32	5 5/16	4 1/4	8 27/64	5 3/4	8 5/16	2 21/64	14 19/64	11 1/32	10 3/64	5 3/64	7/16			
UP10 CENTRAL-THREADED PUMP								1 37/64									

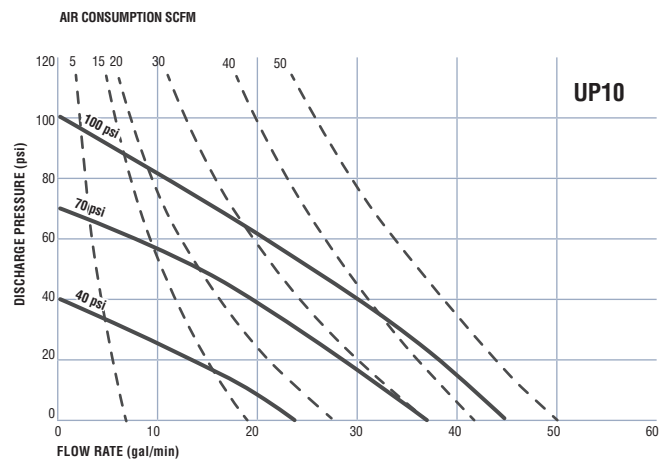
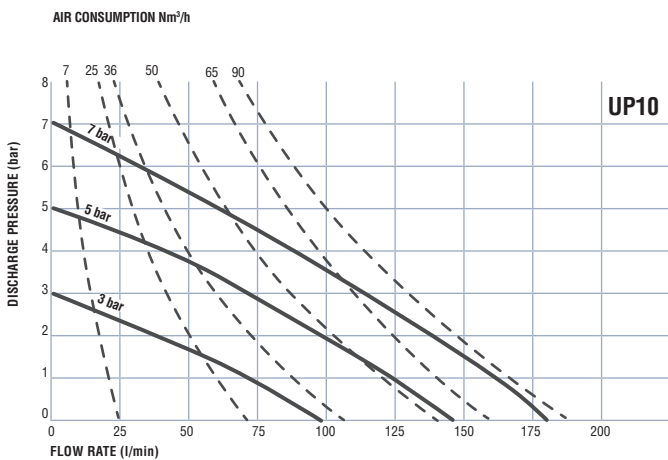

Performance charts with water at room temperature (20 °C - 70 °F)

UP10 SERIES 1" METALLIC PUMPS

The 1" (25 mm) Air Operated Double Diaphragm Pumps made of cast metal can reach a flow rate of up to 200 l/min (52 gal/min) and they offer a wide range of construction materials and porting configurations. The pump design ensures high abrasion resistance when pumping abrasive media and low flow resistance.

Multiple threaded inlet and outlet position options provide maximum installation versatility. Manifolds can rotate 180° to increase installation possibilities.

MAIN APPLICATIONS

- OIL & GAS, PETROCHEMICAL
- MINING & CONSTRUCTION
- PULP & PAPER
- CHEMICAL PLANT PROCESSING
- PAINTS & COATINGS
- TEXTILES, LEATHERS & GARMENTS
- PLANT AND MECHANICAL ENGINEERING
- WASTEWATER & WATER TREATMENT
- MARINE
- CERAMICS
- ENERGY
- ELECTRONICS
- LUBRICATION EQUIPMENT

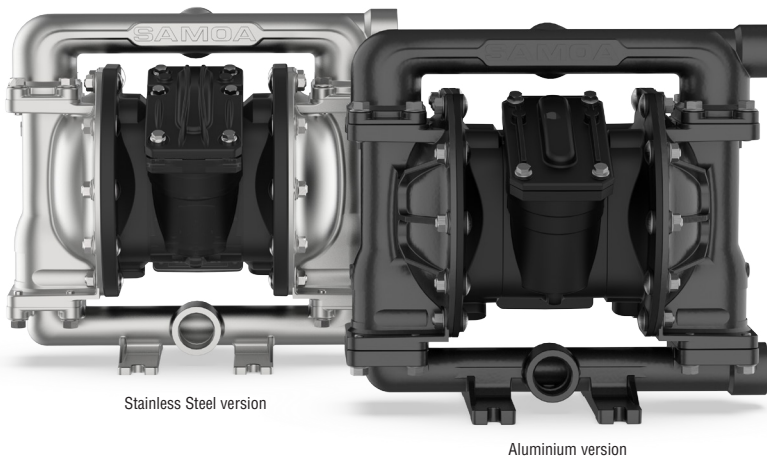

Stainless Steel version

Aluminium version

Non contractual pictures.

TECHNICAL DATA

UP10 METALLIC PUMPS

Pressure Ratio	1:1
Maximum Free Delivery	200 l/min (53 US gal/min)
Air pressure range	1,5 to 8 bar (20 to 120 psi)
Solids in suspension, Max. size	6,4 mm (1/4")
Max dry suction lift	5 m (16')
Max wet suction lift	8 m (26')
Displacement per cycle*	0,85 l (0,2gal)
Fluid inlet/outlet ports (Female)	1" NPT (F) Threaded
	1" BSP (F) Threaded
Air Inlet Port (Female)	1/2" NPSM (F)
Air Exhaust Port (Female)	1" NPT (F)
Sound level	75 dB (A) @50 cycles/min @70 psi
Weight	Aluminium pump
	Stainless Steel pump
	11,5 kg (25 lb) 17,5 kg (38.6 lb)

* Delivery per cycle depends on the diaphragms material, air inlet pressure and fluid viscosity.

PUMP NOMENCLATURE

Examples: **UP10X-XXX-XXX**
UE10X-XXX-XXX-X

UP10X		XXX			XXX			X
PUMP TYPE		AIR MOTOR	HOUSINGS		WETTED PARTS			ACCESSORIES
1 Pump Type & Size	2 Central Body & Air Chambers	3 Fluid Ports / Location Multiport manifolds: central or lateral	4 Fluid Chambers & Manifolds	5 Hardware Bolts	6 Valve Seats	7 Valve Balls	8 Diaphragms Type & Material	9 Accessories (UE pumps only)
UP10 Universal Pump (Bolted) UE10 Universal Pump (Bolted) with electronic interface	ATEX Certified A* = Aluminium B* = Conductive Polypropylene (black)	B = 1" BSP threaded ports N = 1" NPT threaded ports	ATEX Certified A* = Aluminium S* = AISI 316 Stainless Steel	C = Carbon Steel S = Stainless Steel	A = Aluminium H = Hytrel® M = Santoprene® N = Nitrile (Buna-N) S = AISI 316 Stainless Steel V = FKM (Viton®)	H = Hytrel® M = Santoprene® N = Nitrile (Buna-N) T = PTFE (Teflon®) V = FKM (Viton®)	A = Santoprene® C = Hytrel® G = Nitrile (Buna-N) V = FKM (Viton®) Two piece Z = PTFE (Teflon® with Santoprene® backer)	A = Diaphragm leak detectors B = Diaphragm leak detectors (ATEX) C = Stroke sensor D = Stroke sensor (PLC) E = Stroke sensor (ATEX) F = Diaphragm leak detectors + Stroke sensor G = Diaphragm leak detectors + Stroke sensor (PLC) H = Diaphragm leak detectors + Stroke sensor (ATEX)

* **ATEX Certified pumps** for use in hazardous locations ATEX Group II 2GDx.

Hytrel® is a registered trademark of the DuPont Company, Viton® & Teflon® of the Chemours Company and Santoprene® of the Monsanto Company, licensed for Advanced Elastomer Systems, L.P. Kynar® is a registered trademark of Arkema, Inc.

1" (25 mm) METALLIC PUMPS: DIMENSIONS AND PERFORMANCE CHARTS

UP10 ALUMINIUM THREADED PUMPS

UP10 STAINLESS STEEL THREADED PUMPS

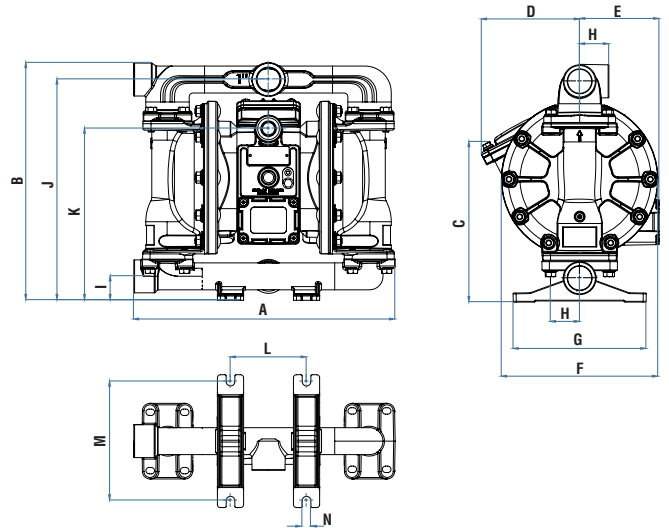
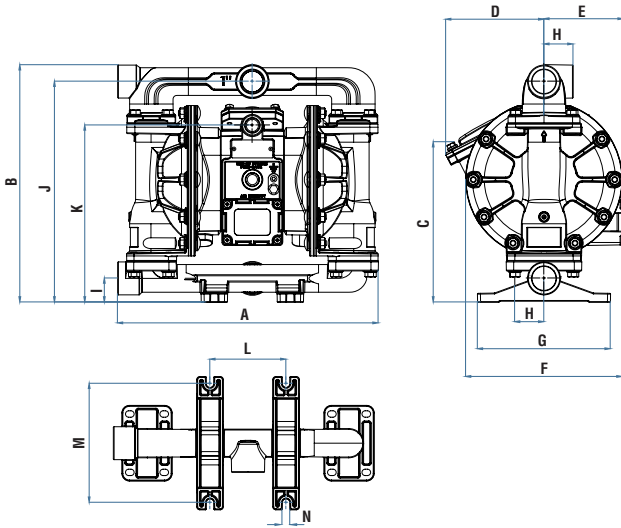

DIMENSIONS (mm)

UP10 ALUMINIUM & STAINLESS STEEL PUMP

A	B	C	D	E	F	G	H	I	J	K	L	M	N
348	317	214	131	106	209	177	39	32	295	237	102	159	10

DIMENSIONS (inches)

UP10 ALUMINIUM & STAINLESS STEEL PUMP

A	B	C	D	E	F	G	H	I	J	K	L	M	N
13 45/64	12 31/64	8 27/64	5 5/32	4 11/64	8 15/64	6 31/32	1 17/32	1 17/64	11 39/64	9 21/64	4 1/64	6 17/64	15/64

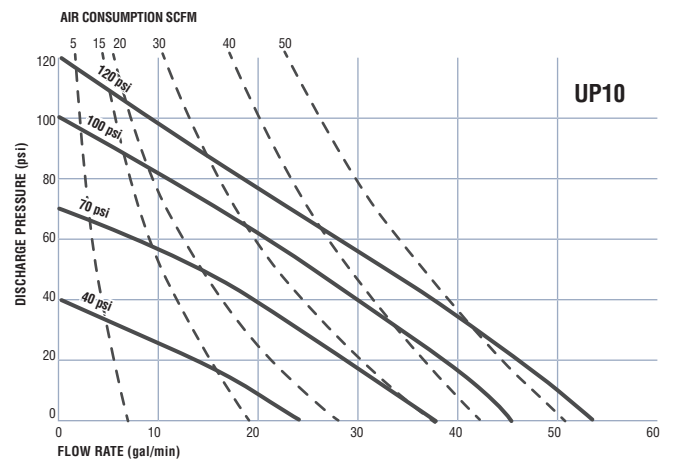
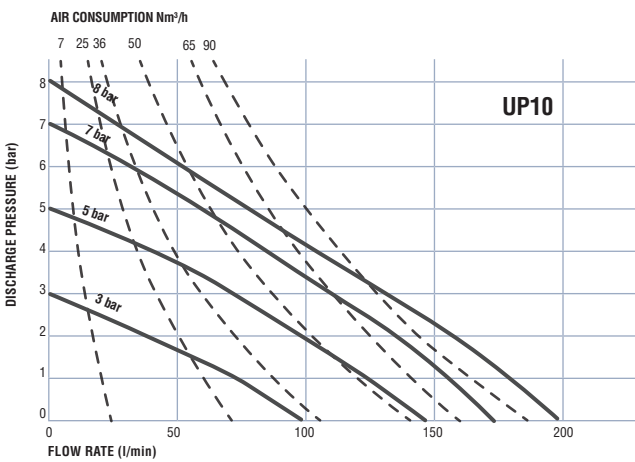

Performance charts with water at room temperature (20 °C - 70 °F)

UP20 SERIES 2" NON-METALLIC PUMPS

The 2" (51 mm) Air Operated Diaphragm Pumps made of injected moulded plastic parts can reach a flow rate up to 650 l/min (172 gal/min). They are available in natural or conductive polypropylene and PVDF for optimum fluid compatibility.

Side off-set inlet and outlet ports to avoid eventual material leaks onto the pump footprint. Manifolds can rotate 180° for maximum pump installation versatility. The flanged bolted ports meets both DIN and ANSI standards.



Polypropylene version

Non contractual picture.

MAIN APPLICATIONS

- OIL & GAS/PETROCHEMICAL
- PAINT & COATING INDUSTRY
- CHEMICAL PROCESSING
- WASTE WATER/WATER TREATMENT
- FILTER PRESS (WATER DISPOSAL)
- PLANT & MECHANICAL ENGINEERING
- PULP & PAPER/CARDBOARD
- POWER STATIONS (ENERGY)
- TANK FARM/BULK TRANSFER

TECHNICAL DATA

UP20 NON-METALLIC PUMPS

Pressure Ratio	1:1
Maximum Free Delivery	650 l/min (172 US gal/min)
Air pressure range	1,5 to 7 bar (20 to 100 psi)
Solids in suspension, Max. size	6,4 mm (1/4")
Max dry suction lift	5 m (16')
Max wet suction lift	8 m (26')
Displacement per cycle*	4,5 l (1.2 gal)
Fluid inlet/outlet ports (Flanged)	2" ANSI/DIN. Side Ends.
Air Inlet Port (Female)	3/4" NPT (F)
Air Exhaust Port (Female)	1 1/2" NPT (F)
Sound level	85 dB (A) @ 50 cycles/min @ 70 psi
Weight	
Polypropylene version	42 kg (92 lb)
Conductive Polypropylene version	46 kg (102 lb)
PVDF version	54 kg (119 lb)

* Delivery per cycle depends on the diaphragms material, air inlet pressure and fluid viscosity.

PUMP NOMENCLATURE

Examples: **UP20B-XXX-XXX**
UE20B-XXX-XXX-X

UP20X		XXX			XXX			X
PUMP TYPE		AIR MOTOR	HOUSINGS		WETTED PARTS			ACCESSORIES
1 Pump Type & Size	2 Central Body & Air Chambers	3 Fluid Ports / Location	4 Fluid Chambers & Manifolds	5 Hardware Bolts, Nuts & Inserts	6 Valve Seats	7 Valve Balls	8 Diaphragms Type & Material	9 Accessories (UE pumps only)
UP20 Universal Pump (Bolted) UE20 Universal Pump (Bolted) with electronic interface	ATEX Certified B* = Conductive Polypropylene (black)	F = 2" ANSI/DIN Flanged Ports / Side Ends.	P = Polypropylene (white) W = PVDF (Kynar®) (graphite) <hr/> ATEX Certified B* = Conductive Polypropylene (black)	S = Stainless Steel	P = Polypropylene T = PTFE (Teflon®) V = FKM (Viton®)	H = Hytrel® M = Santoprene® N = Nitrile (Buna-N) T = PTFE (Teflon®) V = FKM (Viton®)	Conventional A = Santoprene® C = Hytrel® G = Nitrile (Buna-N) V = FKM (Viton®) <hr/> Two-piece U = PTFE (Teflon®) with Santoprene® backer) <hr/> Overmolded N = Nitrile (Buna N) H = Hytrel® M = Santoprene® T = PTFE / EPDM (Bonded)	A = Diaphragm leak detectors B = Diaphragm leak detectors (ATEX) C = Stroke sensor D = Stroke sensor (PLC) E = Stroke sensor (ATEX) F = Diaphragm leak detectors + Stroke sensor G = Diaphragm leak detectors + Stroke sensor (PLC) H = Diaphragm leak detectors + Stroke sensor (ATEX)

* **ATEX Certified pumps** for use in hazardous locations ATEX Group II 2GDx.

Hytrel® is a registered trademark of the DuPont Company, Viton® & Teflon® of the Chemours Company and Santoprene® of the Monsanto Company, licensed for Advanced Elastomer Systems, L.P. Kynar® is a registered trademark of Arkema, Inc.

2" (51 mm) NON-METALLIC PUMPS: DIMENSIONS AND PERFORMANCE CHARTS

UP20 NON-METALLIC FLANGED PUMPS

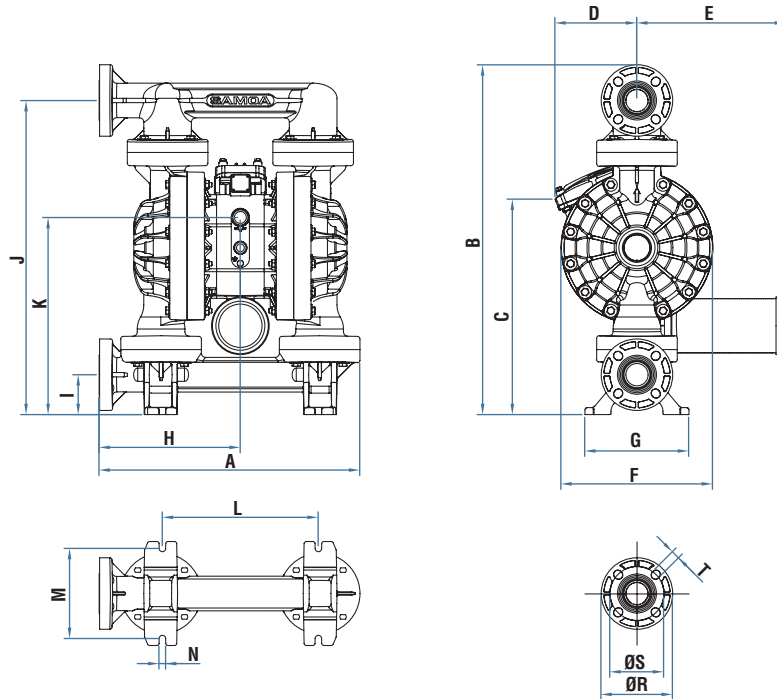

DIMENSIONS (mm)	A	B	C	D	E	F	G	H	I	J	K	L	M	N	R	S	T
UP20 FLANGED PUMP	602	808	497	189	344	350	240	326	92	725	455	360	208	15	165	120,5-125	19
DIMENSIONS (inches)	A	B	C	D	E	F	G	H	I	J	K	L	M	N	R	S	T
UP20 FLANGED PUMP	23 45/65	31 13/16	19 9/16	7 7/16	13 35/64	13 25/32	9 29/64	12 53/64	23/64	28 35/64	17 29/32	14 11/64	8 3/16	19/32	6 1/2	4 3/4-4 59/64	3/4

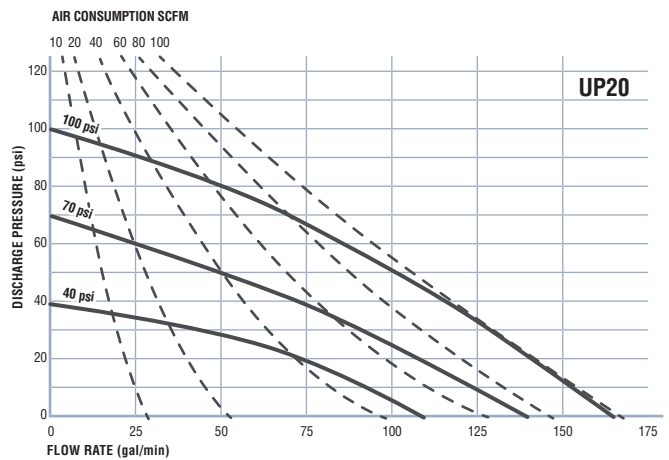
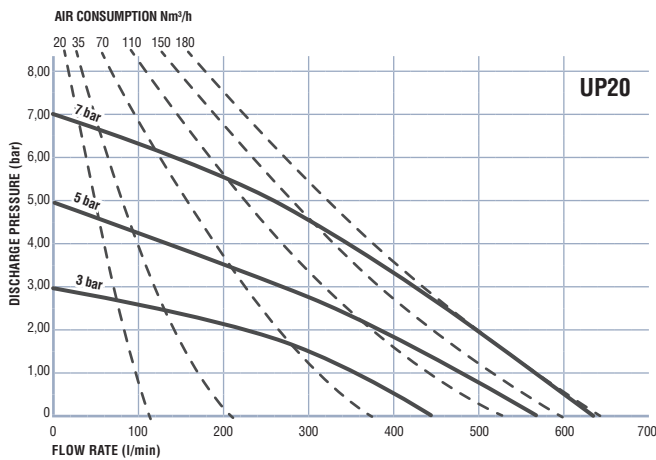

Performance charts with water at room temperature (20 °C - 70 °F)

UP20 SERIES 2" METALLIC PUMPS

The 2" (51 mm) Air Operated Double Diaphragm Pumps made of cast metal can reach a flow rate of up to 650 l/min (172 gal/min) and they offer a wide range of construction materials and porting configurations. The pump design ensures high abrasion resistance when pumping abrasive media and low flow resistance.

Central threaded or flanged inlet and outlet ports available. Manifolds can rotate 180° for maximum pump installation versatility.

MAIN APPLICATIONS

- CERAMIC & PORCELAIN
- PAINT & VARNISH INDUSTRY
- OIL & GAS / PETROCHEMICAL
- WASTE WATER / WATER TREATMENT
- MARINE & SHIPBUILDING
- FILTER PRESS
- MINING & CONSTRUCTION
- CHEMICAL / PROCESSING
- PULP AND PAPER / CARDBOARD

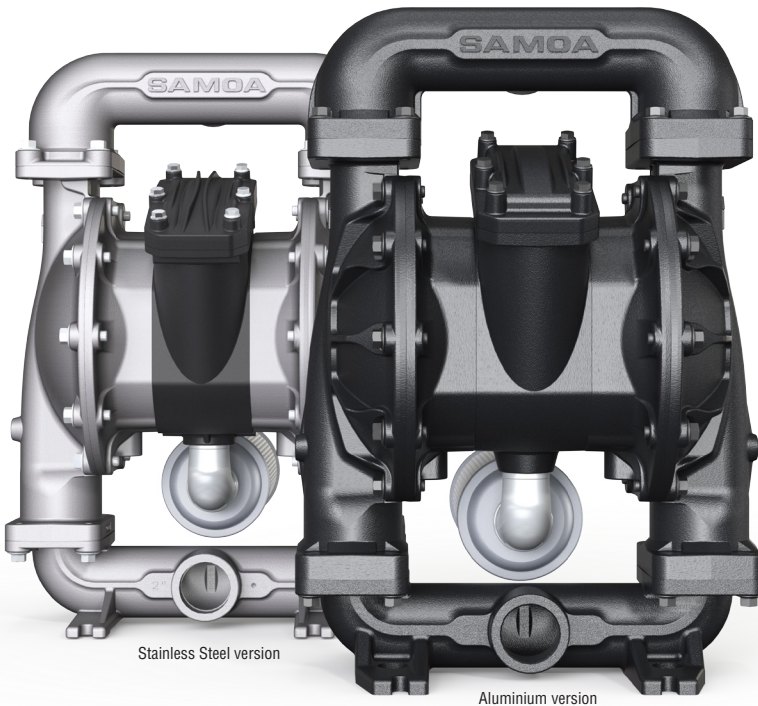

Stainless Steel version

Aluminium version

Non contractual pictures.

TECHNICAL DATA

UP20 METALLIC PUMPS

Pressure Ratio	1:1	
Maximum Free Delivery	650 l/min (172 US gal/min)	
Air pressure range	1,5 to 8 bar (20 to 120 psi)	
Solids in suspension, Max. size	6,4 mm (1/4")	
Max dry suction lift	5 m (16')	
Max wet suction lift	8 m (26')	
Displacement per cycle*	4,5 l (1.2 gal)	
Fluid inlet/outlet ports (Female) (Female)	2" NPT (F) Threaded 2" BSP (F) Threaded 2" ANSI/DIN Flanged	
Air Inlet Port (Female)	3/4" NPT (F)	
Air Exhaust Port (Female)	1 1/2" NPT (F)	
Sound level	85 dB (A) @ 50 cycles/min @ 70 psi	
Weight	Theaded	Flanged
Aluminium version	46 kg (101 lb)	48 kg (106 lb)
Ductile Iron version	74 kg (163 lb)	78 kg (172 lb)
Stainless Steel version	76 kg (168 lb)	82 kg (181 lb)

* Delivery per cycle depends on the diaphragms material, air inlet pressure and fluid viscosity.

PUMP NOMENCLATURE

Examples: **UP20X-XXX-XXX**
UE20X-XXX-XXX-X

UP20X		XXX			XXX			X	
PUMP TYPE		AIR MOTOR		HOUSINGS			WETTED PARTS		ACCESSORIES
1 Pump Type & Size	2 Central Body & Air Chambers	3 Fluid Ports / Location	4 Fluid Chambers & Manifolds	5 Hardware Bolts	6 Valve Seats	7 Valve Balls	8 Diaphragms Type & Material	9 Accessories (UE pumps only)	
UP20 Universal Pump (Bolted) UE20 Universal Pump (Bolted) with electronic interface	ATEX Certified A* = Aluminium L* = Conductive polypropylene with Stainless Steel air chambers S* = AISI 316 Stainless Steel	B = 2" BSP Threaded Ports / Centre horizontal C = 2" ANSI/ DIN Flanged Ports / Centre Horizontal N = 2" NPT Threaded Ports / Centre Horizontal	ATEX Certified A* = Aluminium F* = Ductile Iron S* = Stainless Steel	C = Carbon Steel S = Stainless Steel	A = Aluminium D = AISI 440 Hardened Stainless Steel H = Hytrel® M = Santoprene® N = Nitrile (Buna-N) S = AISI 316 Stainless Steel T = PTFE (Teflon®) V = FKM (Viton®)	H = Hytrel® M = Santoprene® N = Nitrile (Buna-N) S = AISI 316 Stainless Steel T = PTFE (Teflon®) V = FKM (Viton®)	Conventional A = Santoprene® C = Hytrel® G = Nitrile (Buna-N) V = FKM (Viton®) Two-piece Z = PTFE (Teflon®) with Santoprene® backer Overmolded H = Hytrel® M = Santoprene® N = Nitrile (Buna N) T = PTFE / EPDM (Bonded)	A = Diaphragm leak detectors B = Diaphragm leak detectors (ATEX) C = Stroke sensor D = Stroke sensor (PLC) E = Stroke sensor (ATEX) F = Diaphragm leak detectors + Stroke sensor G = Diaphragm leak detectors + Stroke sensor (PLC) H = Diaphragm leak detectors + Stroke sensor (ATEX)	

* **ATEX Certified pumps** for use in hazardous locations ATEX Group II 2GDx.

Hytrel® is a registered trademark of the DuPont Company, Viton® & Teflon® of the Chemours Company and Santoprene® of the Monsanto Company, licensed for Advanced Elastomer Systems, L.P. Kynar® is a registered trademark of Arkema, Inc.

2" (51 mm) METALLIC PUMPS: DIMENSIONS AND PERFORMANCE CHARTS

UP20 ALUMINIUM FLANGED PUMPS

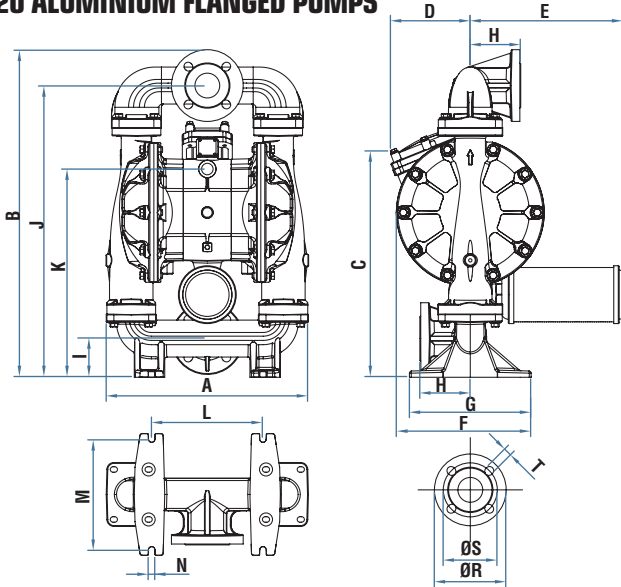

UP20 ALUMINIUM THREADED PUMPS

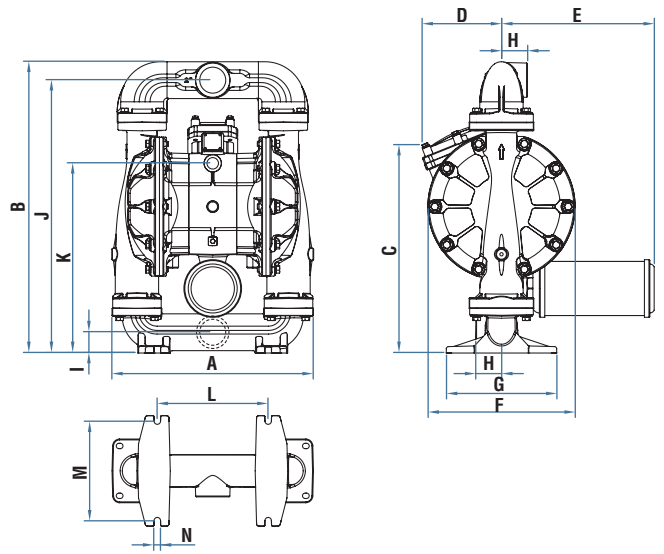

UP20 STAINLESS STEEL/IRON FLANGED PUMPS

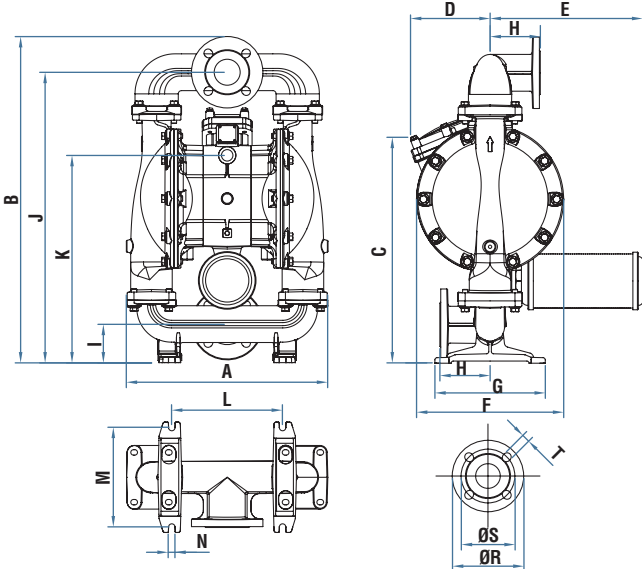

UP20 STAINLESS STEEL/IRON THREADED PUMPS

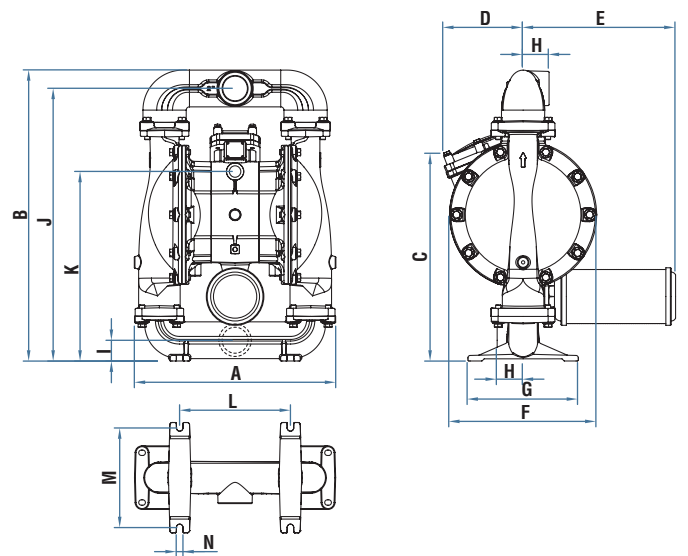

DIMENSIONS (mm)	A	B	C	D	E	F	G	H	I	J	K	L	M	N	R	S	T
UP20 FLANGED PUMP	465	754	251	184	353	340	255	116	89	671	479	256	230	15	165	120,6-125	19
UP20 THREADED PUMP	465	672	480	184	353	340	255	60	48	630	438	256	230	15	-	-	-

DIMENSIONS (inches)	A	B	C	D	E	F	G	H	I	J	K	L	M	N	R	S	T
UP20 FLANGED PUMP	18 5/16	29 11/16	9 7/8	7 1/4	13 57/64	13 25/64	10 3/64	4 9/16	3 1/2	26 27/64	18 55/64	10 5/64	9 1/16	19/32	6 1/2	4 3/4-4 59/64	3/4"
UP20 THREADED PUMP	18 5/16	26 29/64	18 57/64	7 1/4	13 57/64	13 25/64	10 3/64	2 23/64	1 57/64	24 51/64	17 1/4	10 5/64	9 1/16	19/32	-	-	-

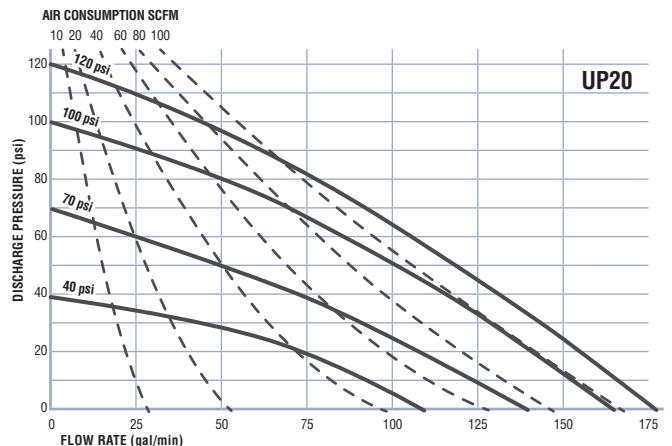
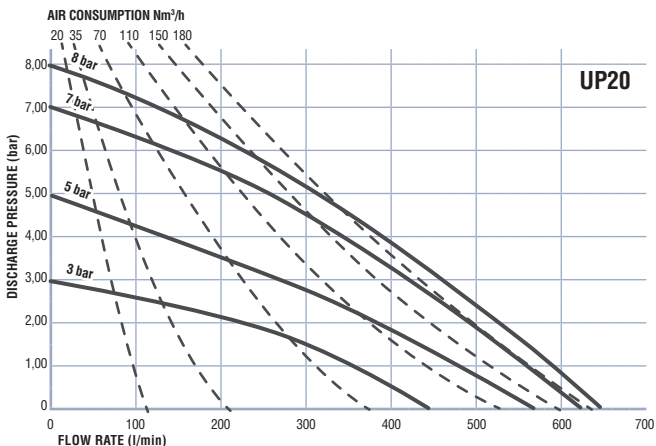

Performance charts with water at room temperature (20 °C - 70 °F)

UP30 SERIES 3" METALLIC PUMPS

The 3" (76 mm) Air Operated Double Diaphragm Pumps made of cast metal can reach a flow rate of up to 1.000 l/min (264 gal/min) and they offer a wide range of construction materials and porting configurations. The pump design ensures high abrasion resistance when pumping abrasive media and low flow resistance.

Central threaded or flanged inlet and outlet ports available. Manifolds can rotate 180° for maximum pump installation versatility.



Aluminium version

Non contractual picture.

PUMP NOMENCLATURE

Examples: **UP30A-XXX-XXX**
UE30A-XXX-XXX-X

UP30X		XXX			XXX			X
PUMP TYPE	AIR MOTOR	HOUSINGS			WETTED PARTS			ACCESSORIES
1 Pump Type & Size	2 Central Body & Air Chambers	3 Fluid Ports / Location	4 Fluid Chambers & Manifolds	5 Hardware Bolts	6 Valve Seats	7 Valve Balls	8 Diaphragms Type & Material	9 Accessories (UE pumps only)
UP30 Universal Pump (Bolted) UE30 Universal Pump (Bolted) with electronic interface	ATEX Certified A* = Aluminium	B = 3" BSP Threaded Ports / Centre Horizontal C = 3" ANSI/DIN Flanged Ports / Centre Horizontal N = 3" NPT Threaded Ports / Centre Horizontal	ATEX Certified A* = Aluminium S* = Stainless Steel	C = Carbon Steel S = Stainless Steel	A = Aluminium D = AISI 440 Hardened Stainless Steel H = Hytrel® M = Santoprene® N = Nitrile (Buna-N) S = AISI 316 Stainless Steel T = PTFE (Teflon®) V = FKM (Viton®)	H = Hytrel® M = Santoprene® N = Nitrile (Buna-N) S = AISI 316 Stainless Steel T = PTFE (Teflon®) V = FKM (Viton®)	Conventional A = Santoprene® C = Hytrel® G = Nitrile (Buna-N) V = FKM (Viton®) Two-piece Z = PTFE (Teflon® with Santoprene® backer)	A = Diaphragm leak detectors B = Diaphragm leak detectors (ATEX) C = Stroke sensor D = Stroke sensor (PLC) E = Stroke sensor (ATEX) F = Diaphragm leak detectors + Stroke sensor G = Diaphragm leak detectors + Stroke sensor (PLC) H = Diaphragm leak detectors + Stroke sensor (ATEX)

* ATEX Certified pumps for use in hazardous locations ATEX Group II 2GDx.

Hytrel® is a registered trademark of the DuPont Company, Viton® & Teflon® of the Chemours Company and Santoprene® of the Monsanto Company, licensed for Advanced Elastomer Systems, L.P. Kyna® is a registered trademark of Arkema, Inc.

MAIN APPLICATIONS

- CERAMIC & PORCELAIN
- PAINT & VARNISH INDUSTRY
- OIL & GAS / PETROCHEMICAL
- WASTE WATER / WATER TREATMENT
- MARINE & SHIPBUILDING
- FILTER PRESS
- MINING & CONSTRUCTION
- CHEMICAL / PROCESSING
- PULP AND PAPER / CARDBOARD

TECHNICAL DATA

UP30 METALLIC PUMPS

Pressure Ratio	1:1	
Maximum Free Delivery	1.000 l/min (264 US gal/min)	
Air pressure range	1,5 to 8 bar (20 to 120 psi)	
Solids in suspension, Max. size	12,7 mm (1/2")	
Max dry suction lift	6 m (19.7')	
Max wet suction lift	8 m (26')	
Displacement per cycle*	10 l (2.6 gal)	
Fluid inlet/outlet ports (Female)	3" NPT (F) Threaded 3" BSP (F) Threaded 3" ANSI/DIN Flanged	
Air Inlet Port (Female)	3/4" NPT (F)	
Air Exhaust Port (Female)	1 1/2" NPT (F)	
Sound level	83 dB (A) @50 cycles/min @70 psi	
Weight	Threaded	Flanged
Aluminium version	64 kg (141 lb)	71 kg (156.5 lb)
Stainless St. version	118 kg (260 lb)	125 kg (275.6 lb)

* Delivery per cycle depends on the diaphragms material, air inlet pressure and fluid viscosity.

3" (76 mm) METALLIC PUMPS: DIMENSIONS AND PERFORMANCE CHARTS

UP30 ALUMINIUM FLANGED PUMPS

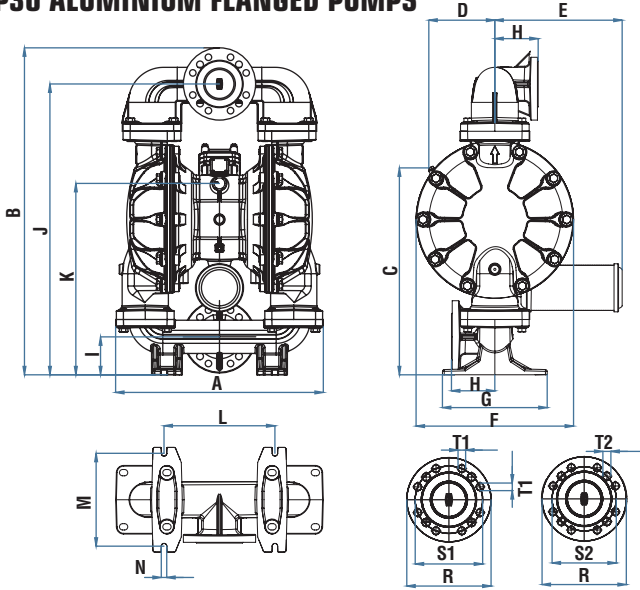

UP30 ALUMINIUM THREADED PUMPS

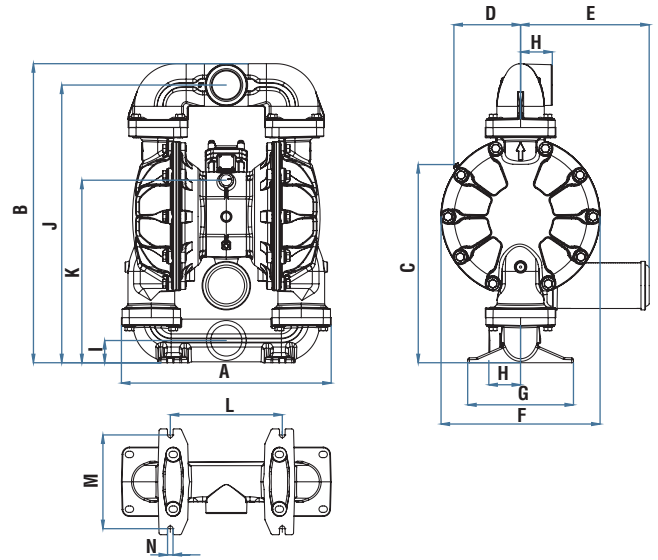

UP30 STAINLESS STEEL FLANGED PUMPS

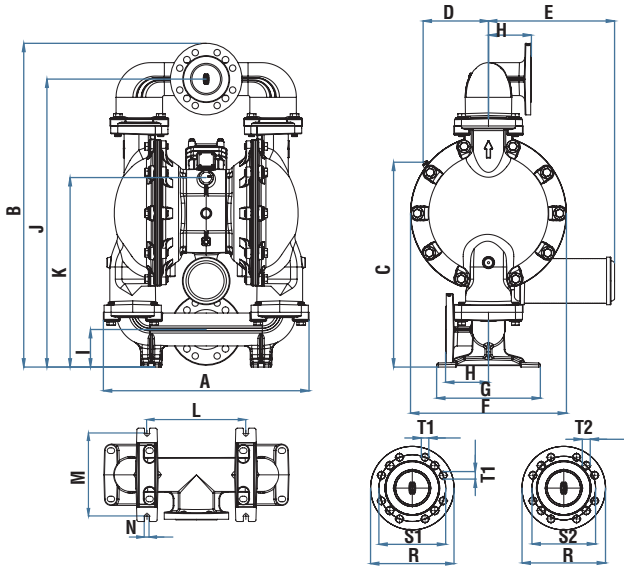

UP30 STAINLESS STEEL THREADED PUMPS

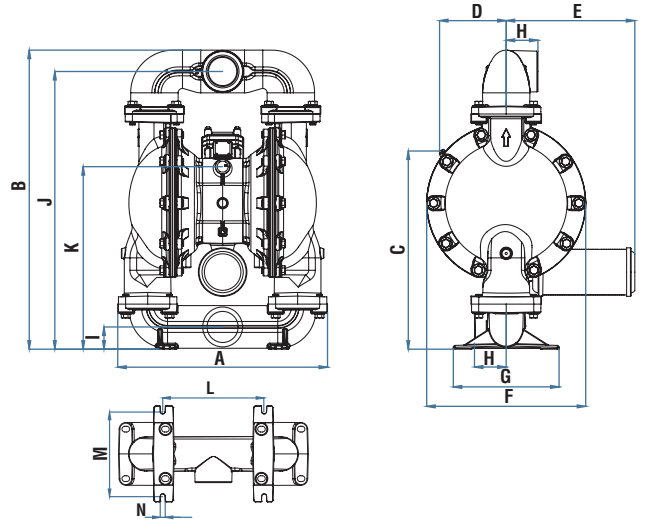

DIMENSIONS (mm)	A	B	C	D	E	F	G	H	I	J	K	L	M	N	R	S1 (DIN)	S2 (ANSI)	T1 (DIN)	T2 (ANSI)
UP30 FLANGED PUMP	575	905	579	183	353	436	290	140	105	805	536	307	257	15	200	160	152.4	21	21
UP30 THREADED PUMP	575	820	543	183	353	436	290	87	61	761	500	307	257	15	-	-	-	-	-

DIMENSIONS (inches)	A	B	C	D	E	F	G	H	I	J	K	L	M	N	R	S1 (DIN)	S2 (ANSI)	T1 (DIN)	T2 (ANSI)
UP30 FLANGED PUMP	21 105/64	35 5/8	22 51/64	7 7/32	13 57/64	17 11/64	11 27/64	5 33/64	4 5/32	31 45/64	21 3/32	12 3/32	10 1/8	19/32	7 7/8	6 5/16	6	53/64	53/64
UP30 THREADED PUMP	21 105/64	32 9/32	21 25/64	7 7/32	13 57/64	17 11/64	11 27/64	3 7/16	2 13/32	29 31/32	19 11/16	12 3/32	10 1/8	19/32	-	-	-	-	-

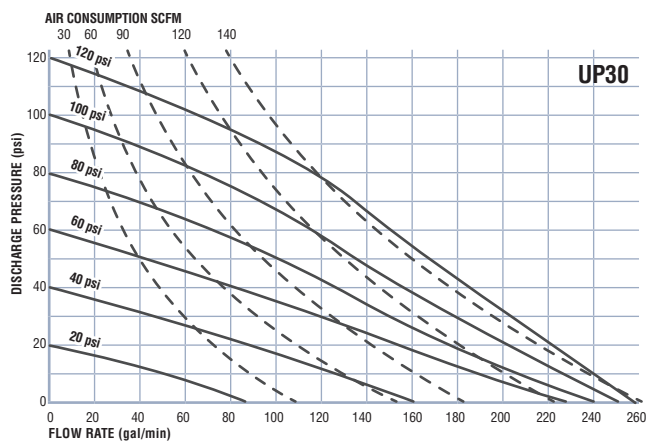
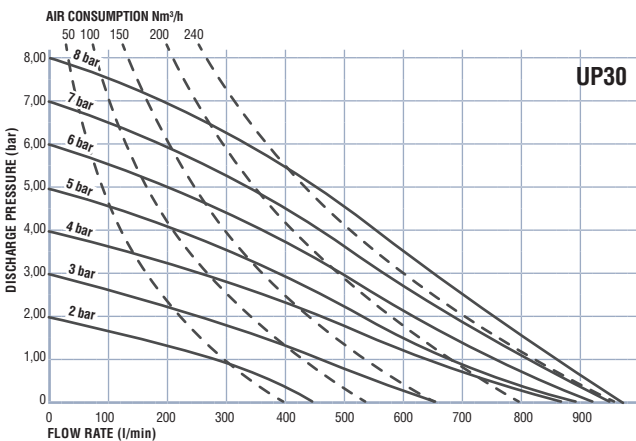

Performance charts with water at room temperature (20 °C - 70 °F)

ACTIVE PULSATION DAMPENERS

When an Air Operated Double Diaphragm Pumps changes stroke direction they do not supply pressure nor flow to the system. This originates pressure fluctuations and flow pulsations. An Active Pulsation Dampener, installed at the pump outlet, minimizes pressure fluctuation on the discharge end, providing a consistent laminar flow.

An Active Pulsation Dampener has an air chamber, connected to compressed air, that keeps a constant pressure on the diaphragm that divides the Dampener in an air and a fluid chamber. When the pump begins the discharge stroke, pressure in the line increases and flexes the diaphragm inward, accumulating fluid in the fluid chamber. Once the pump completes a stroke and redirects its motion, the pressure at the pump outlet decreases and the compressed air in the air chamber flexes the diaphragm outwards, displacing the accumulated fluid into the discharge line.

The dampener size and its materials (chambers and diaphragm) must be selected to be compatible with the corresponding pump.

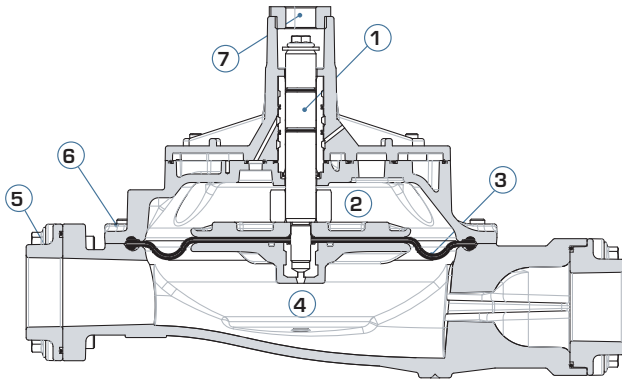

ACTIVE PULSATION DAMPENER

- ① Main valve
- ② Air chamber
- ③ Diaphragm
- ④ Fluid chamber
- ⑤ Fluid inlet/outlet ports NPT/BSP
- ⑥ Bolted fasteners
- ⑦ Air inlet

ADVANTAGES

- Stabilized discharge pressure
- Minimized flow pulsation
- No fluid foam formation
- No fluid splashing
- Less piping vibration
- Equipment protection in long pipe runs and valve protection.
- Bolted construction (leak free)
- Automatic air actuation (Active)
- Easy installation

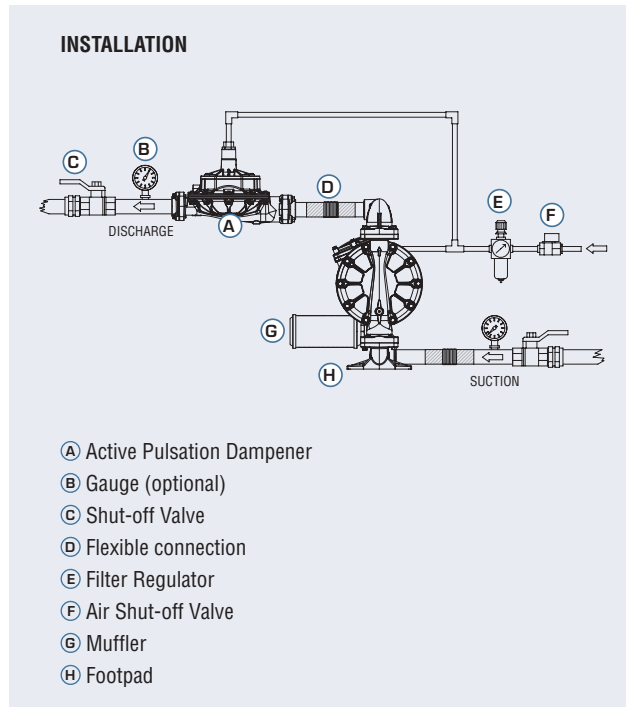

- Ⓐ Active Pulsation Dampener
- Ⓑ Gauge (optional)
- Ⓒ Shut-off Valve
- Ⓓ Flexible connection
- Ⓔ Filter Regulator
- Ⓕ Air Shut-off Valve
- Ⓖ Muffler
- Ⓗ Footpad

ACTIVE PULSATION DAMPENERS - NOMENCLATURE

APDXOX	XXX	X
--------	-----	---

Example: **APD20A-BAC-A**

PULSATION DAMPENER	AIR CONTROL SECTION	WETTED PATH SECTION		FLEXIBLE DIAPHRAGM	
1 Model Type & Size	2 Air Chamber Material	3 Fluid Ports	4 Fluid Chamber Material	5 Fasteners Bolts	6 Diaphragm Material
APD10 1" = 0,25 l. Max Volume For use with 1" pump APD20 2" = 1 l. Max Volume For use with 1 1/2" & 2" pumps APD30 3" = 3,8 l. Max Volume For use with 3" pump	Ⓔ ATEX Certified A* = Aluminium B* = Conductive Polypropylene (black) F* = Ductile Iron S* = Stainless Steel	THREADED PORTS B = BSP (Female) N = NPT (Female) 2" FLANGED PORTS (Non-Metallic APD only) F = ANSI/DIN	P = Polypropylene (white) W = PVDF (Kynar®) (Dark Grey) Ⓔ ATEX Certified A* = Aluminium B* = Conductive Polypropylene (black) F* = Ductile Iron S* = Stainless Steel	C= Carbon Steel S= Stainless Steel	Conventional A = Santoprene® C = Hytre® G = Nitrile (Buna-N) V = FKM (Viton®) Two-piece U (plastic pump versions) = PTFE with Santoprene® backer Z (metal pump versions) = PTFE with Santoprene® backer

* Ⓔ ATEX Certified for use in hazardous locations ATEX Group II 2GDx.
 3" APD available in Aluminium only.

Hytre® is a registered trademark of the DuPont Company, Viton® & Teflon® of the Chemours Company and Santoprene® of the Monsanto Company, licensed for Advanced Elastomer Systems, L.P. Kynar® is a registered trademark of Arkema, Inc.

U·pump

THE SMART PUMP CONTROLLER

SAMOA's U-pump Pump Controllers bring a significant breakthrough in remote actuating, controlling and monitoring pneumatic pumps in industrial process plants.

With this technology, you are able to operate our pumps in the most critical applications or even in challenging process environments, preventing unexpected pump failures and increasing operational efficiency.

U-pump provides real time pumps and tanks Tracking & Monitoring

FEATURES	BENEFITS
Automate and run pumps remotely	Minimize human errors. Boost productivity of the plant as well as that of the operator. Reduce waste by automatically stopping the pump.
Control multiple pumps	Connect various pumps to one single system. Ideal for mixing, blending and proportional batching applications.
Monitor the pumps remotely	Understand process variations. Avoid the pump from running dry. Make necessary plans to run the plant efficiently without disruption. Analyse pump operation time and mean time between failures. Understand the time of breakdown and its reason.
Simple, easy, plug and play system	Can integrate easily to an existing industrial automation system through Third party APIs. User-friendly, easy to operate system.
Diaphragm rupture and leak detection	Avoid spills and leaks, material wastage and environmental hazards. No need of constant monitoring. Less risks to operator.
Tank fill control	Avoid overfilling or underfilling. Boost optimum fluid usage. Ideal for applications like batching, tank filling, repackaging, flushing etc.
Real-time information	Have real-time process information and record all main events. Have preventive maintenance warnings. To see the cycle speed and count. Calculate the volume of fluid displaced. Analyse the material consumption rates. Manage the fluid inventory. See the operator-on-duty.
Warnings & Alerts	Minimize maintenance and downtime costs. Extends pumps life. Reduce breakdowns. Analyse process data. Records all logs of main events.

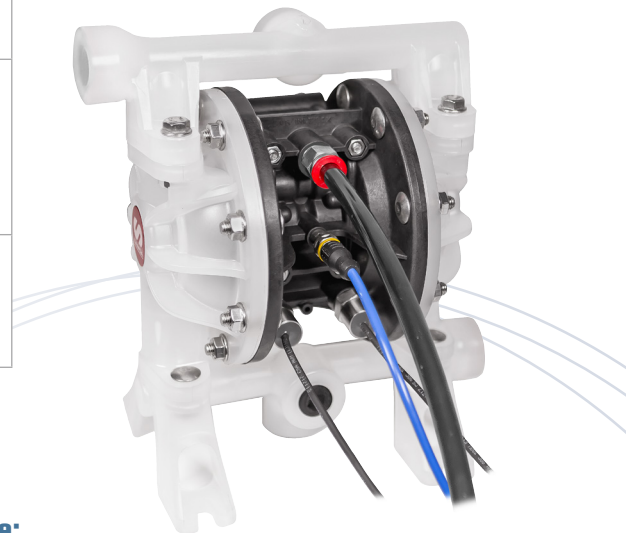

These benefits make the pumps ideal for a variety of applications like:

- Dispensing
- Batching
- Filling
- Sump removal
- Dewatering
- Proportion control
- pH control
- Mixing / Blending
- Repackaging
- Pipe Flushing & Cleaning

U·pump

THE SMART PUMP CONTROLLER

Simple set-up and installation: U-pump is a versatile system, which you can easily adapt to your needs.

U-pump allows to monitor and control main functions of air operated pumps. Each **U-pump** monitor and control module can control and monitor two air operated double diaphragm pumps and two tanks. Several pumps can be connected to form a network thanks to the **U-track** software, included in the **U-net** communications module allowing easy, convenient and effective pump monitoring and control, even from a remote location.

U-net includes a powerful 2.4 GHz processor and 4 GB RAM. It controls the system functions, and it manages the wired and wireless communication between the **U-pump** components. It has two CAN BUS ports (in/out) for wired communications with other **U-pump** components, and an ethernet port that allows **U-net** to connect to the LAN.

Several **U-pumps** can be connected using either a CAN BUS cable or Wi-Fi®. For Wi-Fi® connection, an external CAN BUS to Wi-Fi® converter must be used.

U-pump works with 110 to 240 V, 50 to 60 Hz AC and includes a 24 V DC transformer to energize solenoid valves.

U-pump receives the inputs from different digital and analogic sensors and transmits instructions to solenoid valves that control the pumps. Each **U-pump** module has 2 channels, one for each pump and each tank, and the following input and output ports per channel:

- **Four inputs for digital sensors**, like pump stroke sensor, diaphragm failure sensor, high or low tank level sensor, etc.
- **One input for one analogic sensor**, like an ultrasonic or pressure tank level sensor.
- **One output for an external alarm**. This alarm is programmed to become active whenever a main pump event occurs.
- **One output to control the pump air supply**.
- **One output, common to both channels**, controls a solenoid valve in the general air supply. It can be used as a timer, so the pumps would only operate during working hours.

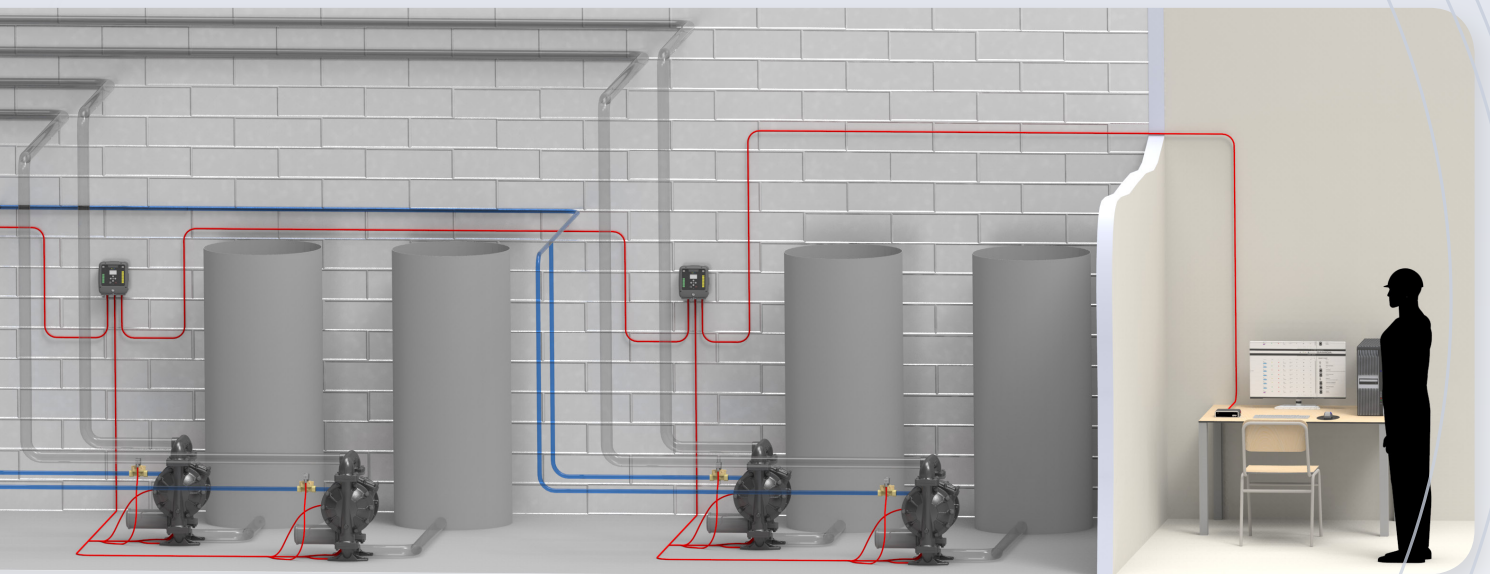

Part No. 383 121
U-pump Monitor and Control Module



PC, tablet and mobile are not included

Part No. 383 321
U-net Communication Unit and U-track software



Part No. 383 210
Can Bus to Wi-Fi® converter

ELECTRONIC INTERFACE ACCESSORIES

Electronic Interface Accessories allow integrating an UP pump into an automated process. The automated process can use PLC controllers or the U-pump system batch and pump controller.

With the use of these accessories and the adequate U-pump system process controller you can monitor and control your pumps remotely, program proactive maintenance interval.

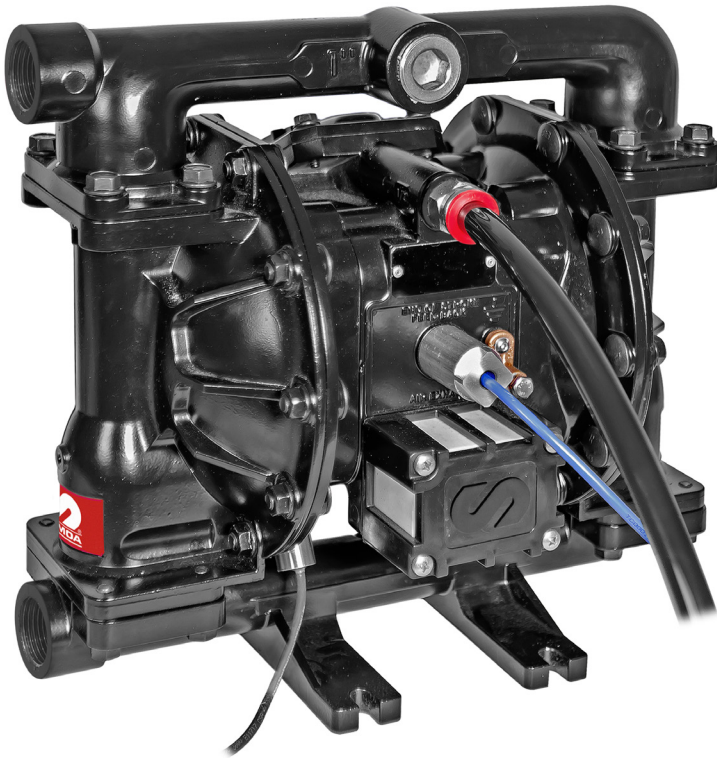

STROKE SENSOR

Inductive sensor that sends an electronic pulse when a pump completes a stroke. They can be used for the following pump functions:

- Preventive maintenance, monitoring total number of cycles to establish a maintenance program.
- Proof of operation, monitoring the cycle rate.
- Prevent pump from running dry, whenever a pump reaches a fixed maximum speed, the pump stops.
- Batching, monitoring pump cycles to reach a specific batch application (Tank filling, formulating, etc.).

Part No. 738 911 Pump cycles counter kit - NPN.

Includes a NPN capacity sensor and 2 m cable. For use with U-pump systems.

Part No. 738 912 Pump cycles counter kit - PNP.

Includes a PNP capacity sensor and 2 m cable. For use with PLC controlled systems.

Part No. 738 913 Pump cycles counter kit - ATEX

Includes a NPN capacity sensor, ATEX certified, 2 m cable and an ATEX barrier. For use with U-pump systems.



LEAK DETECTION

Leak detectors are optic-electric sensors used to detect diaphragm failures. They send an electronic signal as soon as they detect fluid in the pump air chamber as consequence of a diaphragm failure. This signal can be used to control a solenoid valve and stop the pump cutting its compressed air supply.

Part No. 738 909 Leak detector kit

Fits all UE Pivot Series pumps. Includes two optic-electric sensors, one for each air chamber, with 30 cm cable. Can be used with U-pump systems or with a PLC controller.

Part No. 738 910 Leak detector kit, ATEX certified

Fits all UE Pivot Series pumps. Includes two optic-electric sensors, one for each air chamber, with 3 m cable, and an ATEX barrier. Can be used with U-pump systems or with a PLC controller.

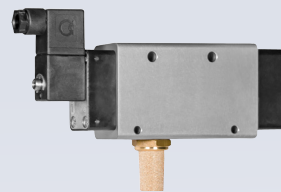

SOLENOID VALVES

24 V Air solenoid valves control the compressed air supply to the pumps. 2/3 solenoid valves, they can be used as normally closed or normally open solenoid valves depending on how they are connected.

Part No. 389 015 1/4" air solenoid valve.

For 3/8" and 1/2" UE and UP pumps.

Part No. 389 017 1/2" air solenoid valve.

For 1" UE and UP pumps

Part No. 389 022 3/4" air solenoid valve.

For 2" and 3" UE and UP pumps.

DIAPHRAGM PUMP MARKETS AND APPLICATIONS



OIL AND GAS. PETROCHEMICAL

- Loading and unloading of tanks, totes, and drums.
- Well stimulation - acidization.
- General utility transfer.
- Cellar pump-out.
- Oil spill clean-up / response.
- Drilling mud make-up.
- Glycol feed.
- Slurry transfer.
- Saltwater transfer and disposal.
- Fuel transfer.



CHEMICAL PLANT PROCESSING

- Loading and unloading tanks, totes and drums.
- Packaging.
- Acids, alkalis, esters, ethers, alcohols, solvents and polymers transfer.
- Dosing.
- Chemical effluent transfers.



MINING AND CONSTRUCTION

- Loading and unloading of tanks and totes.
- Fuel and lubricants transfer.
- Waste fluids and water evacuation.
- Dewatering.
- Cement additives mixing.
- Plaster spraying.
- Soil testing.



PAINTS AND COATINGS

- Loading and unloading of tanks, totes and drums.
- Pigments, solvents and resins transfer.
- Dosing of chemical additives
- Paint filtration.
- Solvent reclamation.
- Filling machines.



PULP AND PAPER

- Loading and unloading tanks, totes and drums.
- Paper treatment chemicals for deinking, chelation, filling, sizing, causticizing, strengthening, etc.
- Rosin, bleach and green liquor transfer.
- Additive dosing.
- Chemical recovery.
- Packaging.
- Starch preparation and transfer.
- Adhesives and ink transfer and dispensing.



TEXTILES, LEATHER & GARMENTS

- Loading and unloading tanks, totes and drums.
- Filter press.
- Dosing.
- Transfer of chemicals agents for desizing, scouring, bleaching, mercerizing, etc.
- Transfer of dyes, pigments, colours, etc.
- Colour formulation and colour spraying.
- Slurry transfer.
- Filtration.
- Effluent & wastewater disposal / dispensing.





PLANT AND MECHANICAL ENGINEERING

- Loading and unloading tanks, totes and drums.
- Filtration.
- Cleaning processes.
- Metal refining.
- Surface treatment (galvanizing, zinc plating, etc.).



MARINE

- Loading and unloading tanks, totes and drums.
- Lubricants and fuel transfer.
- Seepage clean-up.
- Tank strip-outs.
- Dewatering.
- Bilge pumping.



TANK FARMS / BULK TRANSFER

- Loading and unloading tanks, totes and drums.
- Product storage.
- Field treatment.
- Fermentation.
- CIP (Solvent / Nitric Acid / Sodium Hydroxide) transfer.



ELECTRONICS

- Loading and unloading tanks, totes and drums.
- Acid washing.
- Chemical treatment of wafers.
- Silicon slurry transfer.
- Wastewater transfer.



CERAMICS

- Mould filling and cleaning.
- Ceramic slip transfer.
- Glazing and glaze transfer.
- Filter press.
- Waste-water transfer and evacuation.



POWER STATIONS (ENERGY)

- Loading and unloading tanks, totes and drums.
- Transfer of heat transfer fluids in solar plants.
- Water transfer and evacuation.
- Refrigeration.



WASTEWATER AND WATER TREATMENT

- Mobile water systems.
- Wastewater and sewage treatment.
- pH neutralization.
- Sludge removal.
- Irrigation.
- Sampling.
- Drum unloading for chemical injection skids.
- Filtration.

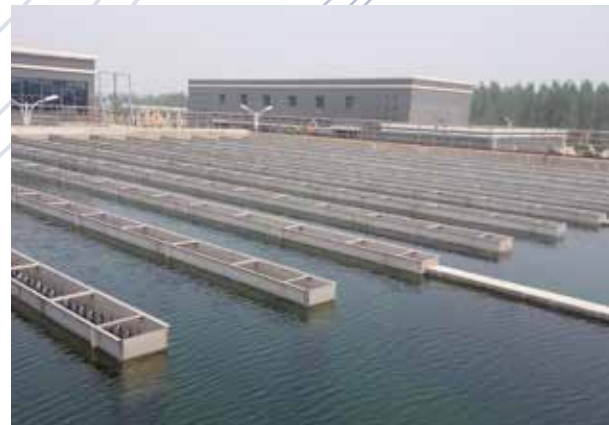



SAMOA INDUSTRIAL, S.A. - HEADQUARTERS

SPAIN AND EXPORT MARKETS
POL. IND. PORCEYO, I-14 - CAMINO DEL FONTÁN, 831
E-33392 GIJÓN (ASTURIAS), SPAIN
TEL.: +34 985 381 488 - FAX: + 34 985 147 213

SAMOA LTD.

UNITED KINGDOM AND REP. OF IRELAND
ASTURIAS HOUSE - BARRS FOLD ROAD
WINGATES INDUSTRIAL PARK
WESTHOUGHTON, BL5 3XP, UK
TEL.: +44 1942 850600 - FAX: +44 1942 812160

SAMOA S.A.R.L.

FRANCE
P.A.E.I. DU GIESSEN
3, RUE DE BRISCHBACH
67750 SCHERWILLER, FRANCE
TEL.: +33 3 88 82 79 62 - FAX: +33 3 88 82 77 88

SAMOA FLOWTECH GMBH

GERMANY, AUSTRIA, SWITZERLAND, THE NETHERLANDS
AND GREECE
AM OBEREICHHOLZ 4
D - 97828 MARKTHEIDENFELD, GERMANY
TEL.: +49 9391 9826 0 - FAX: +49 9391 98 26 50

SAMOA CORPORATION

NORTH AMERICA AND MEXICO
90 MONTICELLO ROAD
WEAVERVILLE, NC 28787, USA
TEL. +1 (828) 645-2290 - FAX: +1 (828) 658 0840

SAMOA CHINA SALES OFFICE

ROOM 8223, BUILDING 2, LANE 1220, ZHOUIJAZUI ROAD
SHANGHAI 200082, P.R. CHINA
TEL. & FAX: +86 21 5515 0064

SAMOA Industrial, S.A. is an ISO 9001, ISO 14001
and ISO 45001 certified company.



CONTACT US TODAY!

Visit www.samoaindustrial.com for more information.